

Accessible Sports Facilities Design Guidelines

2016 Edition



Disability Sport NI

www.dsni.co.uk

Disclaimer

The views expressed in this guide are not intended to take away or diminish the responsibility of the user to comply with current or future legislation. The guidance and recommended standards provided in the guide are intended to complement requirements for Building Regulations, Town Planning Requirements or Licensing, not to replace or override them.

Whilst every effort has been made to ensure the accuracy of these Accessible Sports Facilities Design Guidelines and all information contained herein, Disability Sport NI shall not be held responsible or liable to any party in respect of any loss, damage or costs of any nature arising directly or indirectly from reliance placed on this information.

Issue Tracker

001 - Initial publication December 2016

This publication supersedes Disability Sport NI's Access to Sports Facilities for People with Disabilities: Design and Management Guidelines (2010 Edition).

Image Credits

Disability Sport NI would like to thank Alan Campbell of Sport Northern Ireland; Donal McCann Photography; Taylor Signs and World ParaVolley for permission to reproduce diagrams and images in this publication.

**This document is available in
alternative formats on request**

Contents

List of Figures	6
List of Tables	6
Overview	7
Introduction	8
Disability Sport NI Design and Management Guides	8
About Disability Sport NI	9
Inclusive Sports Facility Advisory Group (ISF Advisory Group)	10
Endorsements	11
How To Use This Guide	12
The Inclusive Sports Facility (ISF) Accreditation Scheme	13
Sports Facilities Design and Technical Guidelines	15
1 Site Wide Accessibility	16
1.1 External Routes and Pathways	16
1.2 Parking and Setting-down Point	19
2 Entrance	25
2.1 Entrance and Entrance Doors	25
2.2 Lobbies	28
2.3 Visitor Reception	28
3 Circulation	31
3.1 Corridors and Passageways	31
3.2 Internal Doors	32
3.3 Vertical Circulation	37
3.4 Handrails and Handholds	45

4	Accessible Sports Facilities and Use of Facilities	47
4.1	Sanitary Provision	47
4.2	Changing Places Toilet Facilities	55
4.3	Baby Changing Facilities	56
4.4	Accessible Changing and Showering	57
4.5	Specific Provisions for Pool and Associated Pool Facilities	68
4.6	Commercial Activities	69
4.7	Fitness Suites and Fitness Equipment	70
4.8	Public Telephones	72
4.9	Outlets, Switches and Controls	72
4.10	Lighting	75
4.11	Visual Contrast	76
4.12	Floor Finishes and Court Markings	78
4.13	Acoustics	79
4.14	Facilities for Assistance Dogs	80
5	Accessible Viewing Areas in Sports Facilities	83
5.1	Accessible Spectator/Viewing Facilities	83
6	Accessible Communications	84
6.1	Signage and Wayfinding	84
6.2	Alarm Systems	89
6.3	Hearing Enhancement Systems	90
6.4	Visual Aids	92
7	Getting Out of the Sports Facility	92
7.1	Exit Routes	92
7.2	Egress	93

8	Sports Specific Access Information	96
8.1	Athletics	96
8.2	Boccia	98
8.3	Cycling	102
8.4	Equestrian	104
8.5	Goalball	105
8.6	Gymnastics	110
8.7	Rowing	112
8.8	Sailing	114
8.9	Swimming	118
8.10	Table Tennis	119
8.11	Volleyball	121
8.12	Wheelchair Basketball	123
8.13	Wheelchair Rugby	126
8.14	Wheelchair Tennis	128
	Appendices	132
Appendix A	Guidance Signpost Bibliography	133
Appendix B	Useful Websites	136
Appendix C	Useful Resources	140

List of Figures

Figure 1	Accessible Parking Bays	20
Figure 2	Typical Layout of Setting-down and Pick-up Point	22
Figure 3	Visitor Reception	30
Figure 4	Door Swing Opening Force Requirements	34
Figure 5	Sports Wheelchair	36
Figure 6	Passenger Lift Car Fit-out	41
Figure 7	Ambulant WC Cubicle; Urinals and Wash hand basins accessible to wheelchair users and ambulant disabled people	50
Figure 8	Unisex Wheelchair Accessible WC	53
Figure 9	Unisex Accessible Peninsular WC for Assisted Use	54
Figure 10	Inclusive Changing Area (with wheelchair accessible incorporated provision)	58
Figure 11	Self-contained Unisex Accessible Changing/Shower/WC Room	62
Figure 12	Outlets, Switches and Controls	74
Figure 13	Assistance Dogs External Spending Area	81
Figure 14	Boccia Court Layout and Markings	101
Figure 15	Goalball Court Layout	109

List of Tables

Table 1	Minimum Entrance Door Width	25
Table 2	Recommended Minimum Corridor Width	32
Table 3	Minimum Internal Door Leaf Width	33
Table 4	Recommended Number, Size and Dimensions of Lifts	38
Table 5	Users Accommodated in Lifts	39
Table 6	Recommended Signage Font Heights	85
Table 7	Field Event Weights	97

Overview

Overview

Introduction

Although physical access to sports facilities in Northern Ireland has improved greatly in recent years, the quality of accessible provision in many facilities still falls short of the sporting needs and expectations of disabled people.

New sports facilities are still often designed to meet the minimum requirements of the Disability Discrimination Act (DDA) and Building Regulations, rather than embracing optimum levels of good practice in accessible design. Indeed, there remains a misconception among some designers that sports facilities built to the standards required by Building Regulations will accommodate all of the needs of people with disabilities.

In fact, the reality is that such sports facilities are often unable to accommodate the needs of a range of sports participants with disabilities, particularly in relation to the requirements of team sports, wheelchair sports and access to fitness equipment.

This guide has been produced by Disability Sport NI to help ensure that new or extended sports facilities in Northern Ireland are designed to meet optimum levels of good practice in terms of access for people with disabilities.

Disability Sport NI Design and Management Guides

This guide is one of a series of four design and management guides produced by Disability Sport NI:

- Guide 1: Accessible Sports Facilities Design Guidelines (2016 Edition)
- Guide 2: Accessible Sports Facilities Management Guidelines (2016 Edition)
- Guide 3: Accessible Sports Stadia Design Guidelines (2016 Edition)
- Guide 4: Accessible Sports Stadia Management Guidelines (2016 Edition)

In addition the following two Guidance Notes have been produced for smaller facilities:

- Disability Sport NI Sports Pavilions Guidance Notes
- Disability Sport NI Boxing Facilities Guidance Notes

The guides and guidance notes aim to promote a greater understanding of inclusive design and management and encourage designers and sports facility/stadia operators to embrace optimum levels of good practice in terms of access for people with disabilities.

By implementing the recommendations in the sports facility design and management guides, designers and sports facility operators can ensure that people with disabilities have a quality experience, increasing over time the number of people with disabilities regularly participating in sport and active recreation.

All guides and guidance notes are available from the Disability Sport NI website: www.dsni.co.uk

About Disability Sport NI

Disability Sport NI is Northern Ireland's main disability sports charity working with people who would like to participate in sport and active recreation.

We work with people with physical, sensory and learning disabilities of all ages, and with schools, disability groups, sporting organisations and clubs to ensure that everyone can gain from the health, social and education benefits of sport and active recreation.

We believe that every person with a disability has the right to participate in all aspects of life and are committed to building a more inclusive society where people with disabilities have the same opportunity as non-disabled people to lead a full, active and healthy lifestyle through sport and active recreation.

We also work closely with Sport Northern Ireland and Governing Bodies of sport to ensure that talented disabled sports people have the same opportunity as their non-disabled peers to train, compete and excel in their chosen sport.

Find out more about the work of Disability Sport NI at www.dsni.co.uk

Inclusive Sports Facility Advisory Group (ISF Advisory Group)

This guide has been produced with the support of the ISF Advisory Group, which is a forum established by Disability Sport NI consisting of representatives of the following disability organisations in Northern Ireland who are committed to ensuring that sports facilities and stadia are inclusive of people with disabilities. The ISF Advisory Group is facilitated by All In Access Consultancy under contract to Disability Sport NI.

- Disability Sport NI
- IFA Inclusive Supporters Association NI
- Royal National Institute of Blind People (RNIB)
- Action on Hearing Loss
- Blind Sports Network NI
- Disability Action
- Inclusive Mobility and Transport Advisory Committee (IMTAC)
- Mencap
- Guide Dogs NI
- NI Deaf Sports

The advisory group was established on 20th April 2016 and includes the functions of the now dissolved Inclusive Stadia Advisory Group.

Endorsements

This guide has been developed by Disability Sport NI and endorsed by:



Supporting people with sight loss

How To Use This Guide

This guide is divided into eight sections as explained below:

Sections 1 - 7: Sports Facilities Design and Technical Guidelines

These sections provide technical guidance in relation to each key area of sports facility design, however please note that the recommendations in these sections will vary depending on the size and type of facility. For ease of interpretation we refer to the following four types of facilities in the guide:

- **Fitness Suites** (including exercise studios);
- **Swimming Pool** (Note: leisure and play pool equipment is not covered by this guide);
- **Sports Facilities** (with four courts or less);
- **Large Sports Facilities** (with more than four courts, or facility with courts and swimming pool/s).



Guidance Signpost

- ▶ Guidance Signposts are denoted throughout the document. The guidance signposts provide relevant cross-references to existing accessibility design standards.

Disability Sport NI acknowledges that design criterion required for smaller sports pavilions and boxing facilities will vary, in some instances, from the recommended standards contained within this guide. Accordingly, separate Disability Sport NI guidance notes are available for **'Sports Pavilions'** and **'Boxing Facilities'**.

Note: Disability Sport NI considers a Sports Pavilion to be: a building which contains only limited changing facilities and toilet facilities; which may, or may not, include an additional meeting/committee room and is without a sports hall or fitness suite.

Section 8: Sports Specific Access Information

This section supplements the design and technical guidelines by providing sports specific disability access information in relation to the specific technical requirements of some of the most popular disability or Paralympic sports. **This section only applies to sports facilities designed as centres of excellence for a particular sport.**

It is acknowledged that on many occasions it may be difficult to apply the recommendations in this guide when adapting existing sports facilities. However, Disability Sport NI encourages designers to implement as many of the recommended standards as is reasonably practicable.

The Inclusive Sports Facility (ISF) Accreditation Scheme

The ISF Accreditation Scheme has been developed by Disability Sport NI to encourage and recognise excellence in the design and management of sports facilities which meet optimum levels of good practice in terms of access for people with disabilities.

The accreditation scheme is awarded to sports facilities who successfully meet the recommendations outlined in the following two Disability Sport NI design and management guides:

- Guide 1: Accessible Sports Facilities Design Guidelines (2016 Edition)
- Guide 2: Accessible Sports Facilities Management Guidelines (2016 Edition)

Two levels of ISF Accreditation are available as follows:

- ISF Excellence Accreditation: this level of accreditation is concerned with the achievement of optimum levels of good practice and is applied to all new facilities.
- ISF Accreditation: this level of accreditation is concerned with the achievement of best possible practice within existing, extended or refurbished sports facilities.

The ISF Accreditation Scheme provides District Councils and other sports facility operators with a mechanism to ensure that new, extended or refurbished sports facilities meet the sporting needs of people with disabilities.

To find out more about the ISF Accreditation Scheme, contact Disability Sport NI.

Disability Sport NI
Unit F, Curlew Pavilion
Portside Business Park
189 Airport Road West
Belfast
BT3 9ED
Telephone: 028 9046 9925
Textphone: 028 9046 3494
Email: email@dsni.co.uk

Sections

1-8

Sports Facilities Design and Technical Guidelines

- 1 Site Wide Accessibility
- 2 Entrance
- 3 Circulation
- 4 Accessible Sports Facilities and Use of Facilities
- 5 Accessible Viewing Areas in Sports Facilities
- 6 Accessible Communications
- 7 Getting Out of the Sports Facility
- 8 Sports Specific Access Information

1 Site Wide Accessibility

1.1 External Routes and Pathways

Overview

It is essential that sports facilities are designed to ensure that access for people with disabilities is considered in terms of the site and not just within the building itself. Accordingly, sports facility designers are required to meet standards of good practice in relation to the design of parking facilities, setting-down points, external pathways and entrances. To allow for easy, unrestricted movement on external routes by the public, including people with disabilities, accessible paths of a high standard should be provided between the following areas:

- From bus/rail stops, near to or within the site, to the entrance.
- From the public highway to the entrance.
- From accessible car parking bays to the entrance.
- From the setting-down point to the entrance.

Note: where external pathways are outside a sports facility, designers should influence this as far as practicable in discussion with the Department of Infrastructure and as part of any overall planning strategy.

1.1.1 Design of external routes and pathways

Recommended Standards

- Pathways leading to the entrance and on escape routes should be a minimum of 2000mm wide.¹
- Pathway surfaces should be firm, slip resistant and smooth. Cobbles, sand or loose gravel surfaces are not acceptable.
- Splay corners should be used on pathways to facilitate wheelchair manoeuvring.
- Where feasible, provide pedestrian routes clearly defined from vehicular routes within sports facility grounds using a kerbline.
- Pedestrian routes should be separate from cycle paths where the latter are provided within sports facility grounds. Cycle paths should have appropriate tactile paving at the start and end of the route to assist people who are blind or partially sighted.

¹ For external pathways to sports pavilions see Sports Pavilions Guidance Notes available from Disability Sport NI.

- Street furniture such as lamp posts, signposts, litter bins, seating and cycle racks should be located beyond the edge of pathways ensuring that there is a minimum 2000mm clear width throughout the length of the path.
- Where bollards are used, they should be minimum 1000mm high. Bollards should contrast visually against the background in which they are seen and have a minimum 150mm deep visually contrasting band to the top.
- Drainage gullies and grates should be located beyond the edge of pathways ensuring that there is a minimum 2000mm clear width throughout the length of the path.
- Tactile paving (buff-coloured and blister profile) should be used to provide warning and guidance to people who are blind or partially sighted when approaching a dropped kerb, or at a junction with a road or car park.
- Avoid windows, outwardly opening doors and other objects projecting onto pathways. Where these are unavoidable, a minimum 1200mm unobstructed pedestrian route should be maintained (firm surface).
- Outwardly opening doors (other than for emergency use) should be protected e.g. using a barrier rail, or recessed.

Additional Considerations

- Pedestrian pathways should be differentiated from cycle paths e.g. using a painted/raised white line.



Accessible approach and entrance, Newry Leisure Centre -
(image courtesy of Donal McCann Photography)



Guidance Signpost

- ▶ BS 8300:2009 +A1:2010. **Paragraph 5.2 & Figure 6** Width and height of an access route, p.17-18 & **Paragraphs 5.7.1.2 - 5.7.2** Free-standing posts and columns & Provision of hazard protection within an access route, p.20-21.
- ▶ Guidance on the use of tactile paving surfaces. **Chapters 1, 5 and 7.** Department for Transport.
- ▶ DD CEN/TS 15209:2008. Tactile paving surface indicators produced from concrete, clay and stone.
- ▶ Cafe Culture: Memorandum of Understanding. Belfast City Centre Management.

1.1.2 Gradient

Note: pathways with a gradient steeper than 1:21 are not regarded as providing suitable access and are not acceptable in new sports facility grounds. Gradient is also an important consideration in refurbished sports facilities.

Recommended Standards

- Pathways should be level wherever possible or have the shallowest possible gradient. The steepest allowable gradient for pathways in new sports facilities is 1:21 and every effort should be made to meet this as part of the development and landscaping works undertaken in refurbishment projects. Consider handrails to offer support on extended ramp gradients/lengths.
- Crossfall gradient on pathways and approach routes should not exceed 1:50.

1.1.3 External ramps and steps

Note: as external steps and ramps are normally only necessary to improve access on paths with a gradient steeper than 1:21 (and gradients steeper than 1:21 are not regarded as providing a good level of access), the use of steps and ramps is not recommended.

1.2 Parking and Setting-down Point

Overview

Many people with disabilities in Northern Ireland travel to sports facilities by private car, taxi or coach therefore in creating inclusive sports facilities, the provision of designated accessible parking bays and setting-down points for visitors with disabilities and for people with disabilities working there is essential. Others, particularly people who are blind or partially sighted, will travel by public transport while others who live nearby will walk or push to the facility.

1.2.1 Designated on-site accessible parking provision

Recommended Standards

- The recommended number of accessible parking bays for sports facilities should be a minimum of two accessible parking bays or 8% of total parking capacity, whichever is the greatest.²
- One additional accessible bay should be provided for each employee regularly working in the facility who is a 'blue badge' holder, differentiated from bays designated for other users.
- Accessible bays should be located as close as possible to the entrance and no more than 100m.
- If accessible parking bays are located more than 50m from the entrance then pathways should be covered to offer weather protection.
- The design of pathways between accessible parking bays and the entrance should comply with the recommended standards specified in Section 1.1 of this guide: External Routes and Pathways.
- See Section 1 of Disability Sport NI Guide 2: Accessible Sports Facilities Management Guidelines (2016 Edition). Sports Facilities Management Policies and Procedures - Management of Accessible Parking Bays.

Additional Considerations

- Include additional provision for large designated parking bays, 4800mm wide by 8000mm long, to cater for commercial vehicles converted for side or rear access using hoists or ramps.



Guidance Signpost

- ▶ BS 8300:2009 +A1:2010. **Paragraphs 4.2.1.1** General provision, p.9.

² Where car parks have more than 500+ spaces a minimum of 6% of accessible car parking spaces may be acceptable, depending on anticipated use. For parking at sports pavilions see Sports Pavilions Guidance Notes available from Disability Sport NI.

1.2.2 Design of accessible parking bays

Recommended Standards

- Accessible parking bays should be in accordance with Figure 1 of this guide: Accessible Parking Bays. They should include a 1200mm safety zone to both sides of each bay (to accommodate a driver or a passenger with disabilities) and to the rear of each bay for boot access and cars with rear hoists.
- Vertical signs are required at the head of each bay as shown in Figure 1, clearly signed for use by 'Blue badge holders only'.
- A dropped kerblines should only be installed along the entire length of an accessible parking zone where it will be complemented by this signage and where it does not present a hazard to pedestrians.
- On a site specific basis, consult with Guide Dogs NI regarding necessity for tactile warning surface along dropped kerblines.
- Bays to be located on firm and level ground.

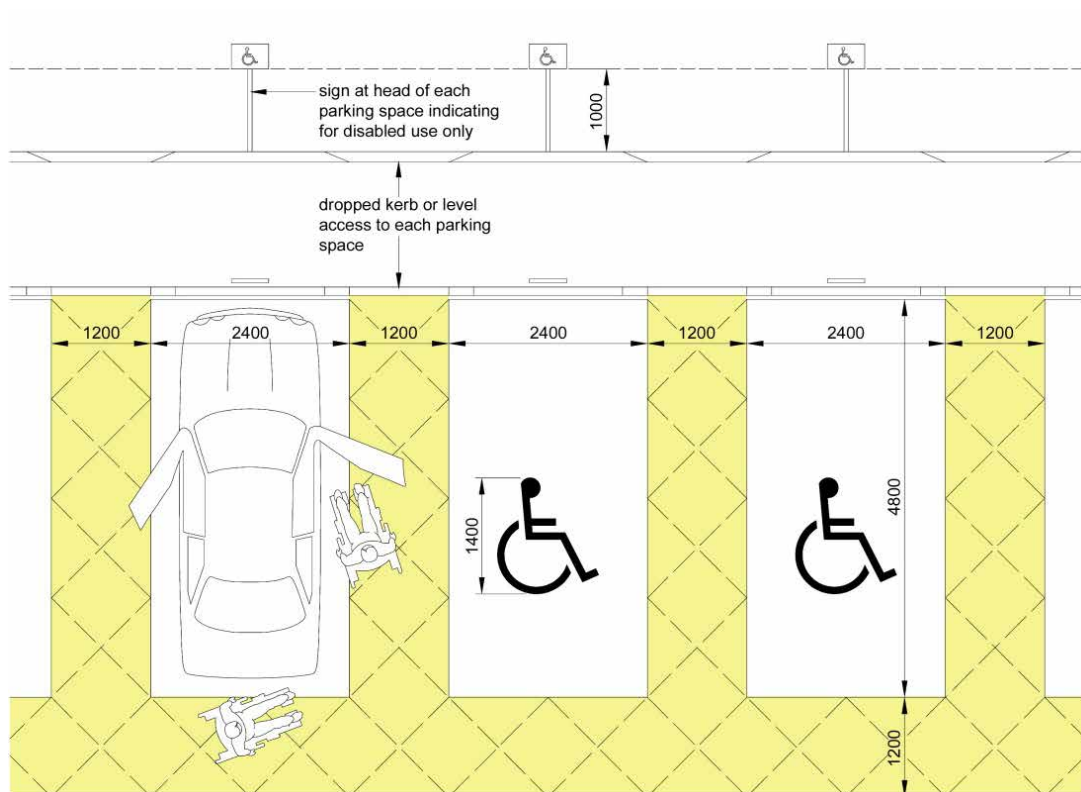

Figure 1 - Accessible Parking Bays



Accessible Parking Bays (Foyle Arena, Derry-Londonderry)

1.2.3 Setting-down and pick-up point

Recommended Standards

- A setting-down/pick-up point suitable for use by cars, taxis and accessible buses within 50m of the entrance and preferably in a covered area.
- Setting-down and pick-up point should be in accordance with Figure 2 of this guide: Typical Layout of Setting-down and Pick-up Point.
- Clearly identified by signage, in accordance with sign design standards, to assist sighted and people who are partially sighted and clearly marked at ground level.
- Long enough to accommodate at least one coach with a tail lift where possible; whereby 8000mm length will be required.
- Level with the surrounding pathway to allow for the convenient transfer of wheelchair users to and from vehicles.

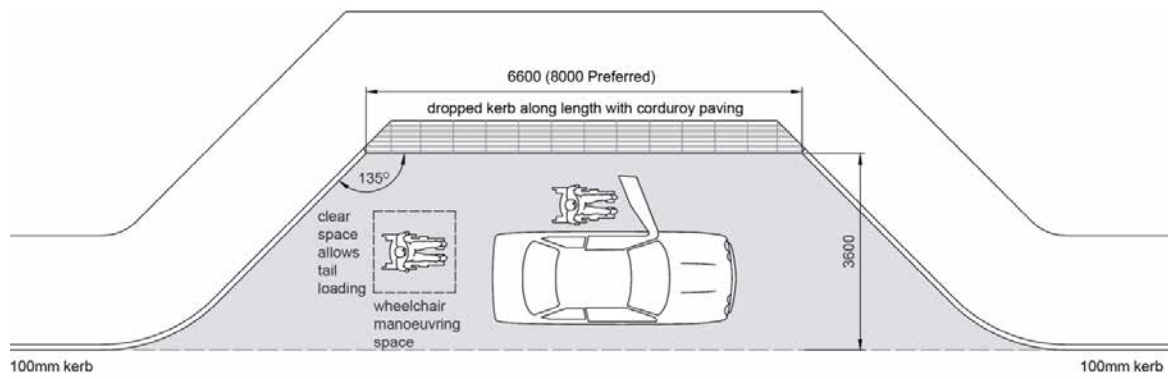

Figure 2 - Typical Layout of Setting-down and Pick-up Point



Setting-down point (signed as 'Drop off only') - Ballymote Sports & Wellbeing Centre, Downpatrick



Guidance Signpost

- ▶ Inclusive Mobility: A guide to best practice on access to pedestrian and transport infrastructure. Department of Transport: **Section 4.7** Information surface; **Sections 6.1 - 6.2** Bus stop overall design; shelters; flags; seating; timetable information.
- ▶ Guidance on the use of tactile paving surfaces. **Chapter 7** Information surface, p.70-72. Department for Transport.
- ▶ DD CEN/TS 15209:2008. Tactile paving surface indicators produced from concrete, clay and stone.

1.2.4 Car park entry and payment

Overview

Where these facilities are applicable, barrier control systems, parking meters, controls and ticket dispensers which can be operated by wheelchair users should be provided.



Guidance Signpost

- ▶ BS 8300:2009 +A1:2010. **Paragraphs 4.4 - 4.4.4.3** Entrance to car parks, and parking controls, p.14-16.

1.2.5 Other parking facilities (mobility scooters, bicycles and buggies)

Design teams should consider the provision, location and design of:

- External and internal scooter parking.
- External bicycle parking areas.
- An internal buggy parking zone for child pushchairs.

Overview

Mobility scooters are increasingly used by people with disabilities and older people as a viable method of moving around e.g. research has shown that 300,000 mobility scooters are used in Britain in 2012 compared to 70,000 five years ago.³ A range of scooter size and speed is available. Scooters have various positive attributes e.g. they can address the difficulties people with disabilities often face getting to and from sports facilities by enabling them to travel greater distances.

The location and design of cycle parking facilities should not impact negatively on people with disabilities approaching sports facilities.

Use and storage provision for buggies (child pushchairs) should be considered.

Recommended Standards

- Cycle racks should be located where they will not cause obstruction on external routes and pathways.
- Cycle racks should be covered by a form of weather protection where possible.
- Cycle racks should be clearly visible through visual contrast with their surroundings e.g. bands of contrast.

Additional Considerations

- Provision for external scooter parking should be made in a secure and preferably covered area close to the entrance.



Guidance Signpost

- ▶ BS 8300:2009 +A1:2010. **Annex C** (informative) **Table C.5** Space required for a sample of electric scooters when stationary, p.188.
- ▶ BS 8300:2009 +A1:2010. **Annex C** (informative) **Table C.10** Space required for users of electric scooters to turn through 90°, p.190.
- ▶ BS 8300:2009 +A1:2010. **Annex C** (informative) **Table C.15** Space required for a user to turn an electric scooter through 180°, p.192.

2 Entrance

2.1 Entrance and Entrance Doors

Overview

It is generally envisaged that sports facilities will be used at least occasionally by people using sports wheelchairs with cambered wheels, therefore facility providers will be required to install doors of the width and type specified in Table 1 of this guide: Minimum Entrance Door Width.

Sport Facility Type	Clear Opening Width (minimum dimensions)	Automatic Doors Required
Sports Pavilions	See Sports Pavilions Guidance Notes available from Disability Sport NI	
Boxing Facilities	See Boxing Facilities Guidance Notes available from Disability Sport NI	
Swimming Pool (with pool/s and associated pool facilities only)	1000mm	No
Fitness Suites (including exercise studios)	1000mm	No
Sports Facilities (with four courts or less)	1000mm*	Yes
Large Sports Facilities (with more than four courts, or facility with courts and swimming pool/s)	1000mm*	Yes
Stadia: See Disability Sport NI Guide 3: Accessible Sports Stadia Design Guidelines (2016 Edition)		

Table 1 - Minimum Entrance Door Width

*Except sports facilities used for wheelchair tennis; whereby the minimum clear opening width of entrance doors should be increased to 1200mm.



Clear signage used to denote location of entrance point
(The Vale Centre, Greysteel)

Recommended Standards

- On approach, the entrance should be clearly identifiable through the use of large clear signage.
- The entrance should be easily distinguishable and should contrast visually with the immediate surroundings.
- The entrance should have a form of weather protection or recessed entrance (unless automatic doors are installed).
- The area immediately in front of the entrance door(s) should be level and spacious to enable easy and unrestricted movement, or during an emergency.
- Entrance thresholds should be level. If a raised threshold is unavoidable it should not exceed a height of more than 15mm and should be clearly visible and be chamfered or pencil rounded.
- Amenity lighting should be provided adjacent to the entrance.
- Revolving doors should not be used.
- Doors that are automatic opening or power operated will assist a broad range of people, including wheelchair users, assistance dog owners and older people and should be provided where practicable in sports facilities. If manual doors are used, a doorbell or intercom should be provided to attract the attention of staff for assistance when required. This facility should be accessible to wheelchair users, should contrast visually with its surroundings and be labelled.
- Where provided, automatic doors should be fitted with safety sensors i.e. controlled by a passive infrared system located in an appropriate position, which is sensitive to children and to people who are seated and can sense someone who is standing.
- Where practicable, automatic entrance doors with a sideward sliding arrangement should be provided. (**Note:** automatic swinging or folding doors can present a hazard to some people with disabilities).
- Automatic entrance doors should be capable of manual operation in the event of a power failure.
- Vision panels to doors should provide a minimum zone of visibility between 500mm and 1500mm above floor level, large enough to enable a standing or seated person to see and be seen from either side of the door.

- Glazed doors and associated side panels should not be frameless. They should be distinguishable from their surroundings, with permanent safety markings such as signs and logos located in the zones 850mm to 1000mm from ground level and 1400mm to 1600mm from ground level.
- Ensure safety markings are visible from both sides of doors.
- Control air ingress by providing a draught lobby, or where this is not feasible, an air curtain can assist.
- Outwardly opening doors (other than for emergency use) should be protected e.g. using a barrier rail, or recessed.



Guidance Signpost

- ▶ Automatic Door Systems. Specifiers' Handbooks for Inclusive Design. Centre for Accessible Environments.
- ▶ CSN EN 16005. Power operated pedestrian doorsets - Safety in use - Requirements and test methods. 2012.
- ▶ BS 8300:2009 +A1:2010. **Paragraph 6.4.3** Vision Panels, p.38-39 & **Paragraph 6.4.4** Glass Doors, p.40.
- ▶ Glazing. Building Regulations (Northern Ireland) 2012 Guidance: Technical Booklet V. **Paragraphs 3.1 - 3.3 & Diagram 3.1**, p.14.



Accessible entrance (Ballymote Sports & Wellbeing Centre, Downpatrick)

2.2 Lobbies

Recommended Standards

- Where lobbies are provided in sports facilities they should be sizeable, to permit a wheelchair user and a companion to rest clear of door swings*. This will also assist parents with pushchairs, persons accompanied by assistance dogs and people using mobility aids/scooters.

*Lobbies used by sports wheelchair users should have a minimum length 2000mm clear from any leading edge of doors (2500mm preferred) and a minimum 2000mm clear width (2500mm preferred).



Guidance Signpost

- ▶ Access to and use of buildings. Building Regulations (Northern Ireland) 2012 Guidance: Technical Booklet R. **Paragraph 3.24 & Diagram 3.4**, p.25-26.
- ▶ Accessible Sports Facilities, Design Guidance Note. **Section 5** Internal Circulation - Lobbies and Figure 8 & 9, p.23-26. Sport England Publications, Wetherby. Sport England 2010.
- ▶ BS 8300:2009 +A1:2010. **Paragraph 7.1.1** Entrance flooring systems, p.47.
- ▶ BS 8300:2009 +A1:2010. **Paragraph 9.1.3** Floor surfaces, p.62-63.

2.3 Visitor Reception



Reception counter with lowered and standing height sections (Amphitheatre Wellness Centre, Carrickfergus)

Overview

The reception should be designed to provide good access for all.⁴ The reception counter should be in sight of the entrance and identifiable by people who are partially sighted.

Recommended Standards

- The approach to the reception area should be direct, free from obstacles and be minimum 2000mm wide.
- A reception counter with an upper and lower section should be provided to facilitate visitors and staff who wish to stand or sit, including wheelchair users and people who are small in stature. See Figure 3 of this guide: Visitor Reception.
- The lower counter section should be located in a prominent position.
- Provide a hearing enhancement system. See Section 6.3 of this guide: Hearing Enhancement Systems.
- Rest seating in a variety of style options is required to assist people with a range of abilities; there should be space to enable wheelchair users to rest alongside seated companions.
- The design of access control systems e.g. control barriers within the reception area should accommodate the needs of people with disabilities.
- Accessible side-hung gates should have an effective clear opening width of minimum 1000mm.
- Security barriers should have non-reflective glass, to assist people who rely on lip reading.
- Signage to indicate that staff assistance is available if required e.g. to assist older people.



Guidance Signpost

- ▶ BS 8300:2009 +A1:2010. **Paragraph 7.1.2** Reception area, p.47

⁴ For reception counters in sports pavilions see Sports Pavilions Guidance Notes available from Disability Sport NI.

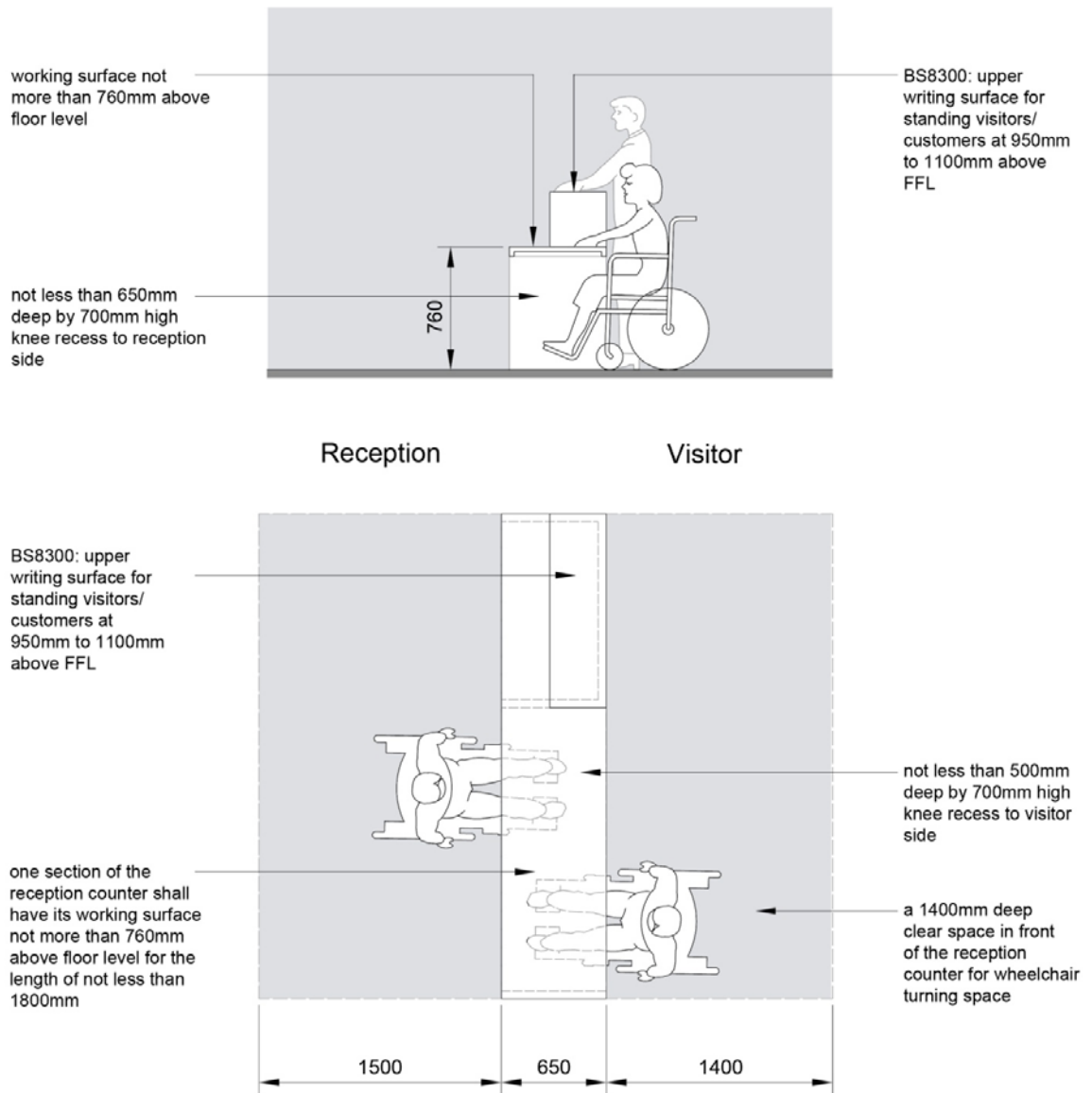

Figure 3 - Visitor Reception



Accessible pass-through gate for inclusive access in reception, Newry Leisure Centre - (image courtesy of Donal McCann Photography)

3 Circulation

3.1 Corridors and Passageways

Overview

Corridors and passageways within sports facilities should be wide enough to accommodate people with disabilities, including within sports facilities where sports wheelchair users and medium to large groups of people with disabilities use facilities at the same time. Accordingly, the recommended minimum width of corridors has been set at a high level as outlined in Table 2 of this guide: Recommended Minimum Corridor Width.

Recommended Standards

- Corridors and passageways should be clutter free circulation routes. Fire extinguishers and hoses, radiators and other objects should not project into the clear corridor width, as they present a potential hazard to people who are blind or partially sighted. It is recommended that such objects be recessed, however if unavoidable, hazard protection is necessary.
- Glazing at the end of corridors and passageways should be avoided.
- Where circulation routes are sub-divided by a series of fire doors the provision of electro-magnetic hold backs should be provided.

Sport Facility Type	Clear Width (minimum dimensions)
Sports Pavilions	See Sports Pavilions Guidance Notes available from Disability Sport NI
Boxing Facilities	See Boxing Facilities Guidance Notes available from Disability Sport NI
Swimming Pool (with pool/s and associated pool facilities only)	1500mm
Fitness Suites (including exercise studios)	1500mm
Sports Facilities (with four courts or less)	1500mm*
Large Sports Facilities (with more than four courts, or facility with courts and swimming pool/s)	2000mm*
Stadia: See Disability Sport NI Guide 3: Accessible Sports Stadia Design Guidelines (2016 Edition)	

Table 2 - Recommended Minimum Corridor Width

* In sports wheelchair zones; corridor width should be minimum 2000mm (2500mm preferred to allow two sports wheelchairs to pass, or at least providing 2500mm passing places maximum 5000mm apart).

3.2 Internal Doors

Overview

To facilitate free and easy movement by large groups of people with disabilities, including people using sports wheelchairs with large cambered wheels, the minimum width of internal doors has been set at a high level as specified in Table 3 of this guide: Minimum Internal Door Leaf Width.

Recommended Standards

- Doors should have at least one leaf that provides the minimum effective clear door opening width specified in Table 3.

Sport Facility Type	Clear Width (minimum dimensions)
Sports Pavilions	See Guidance Notes for Sports Pavilions available from Disability Sport NI
Boxing Facilities	See Boxing Facilities Guidance Notes available from Disability Sport NI
Fitness Suites (including exercise studios)	875mm
Swimming Pool (with pool/s and associated pool facilities only)	875mm
Sports Facilities (with four courts or less)	875mm*
Large Sports Facilities (with more than four courts, or facility with courts and swimming pool/s)	875mm*
Stadia: See Disability Sport NI Guide 3: Accessible Sports Stadia Design Guidelines (2016 Edition)	

Table 3 - Minimum Internal Door Leaf Width

* Except in sports wheelchair zones, whereby minimum door width should be 1000mm (increased to 1200mm to facilitate tennis wheelchairs). This criterion applies also to accessible toilet provisions and accessible changing provisions.

Note: a minimum unobstructed door opening of 1000mm can be achieved using:

- A single leaf door set allowing for a door leaf which achieves a clear width of 1000mm.
- An asymmetric arrangement incorporating a door set of 2000mm with one door leaf of 1000mm and a second door of a smaller width.
- Increase the corridor width to a width greater than the recommended 2000mm, to accommodate 2 x 1000mm doors plus the door frame.
Note: in some situations the use of cranked hinge ironmongery can improve access through door openings by carrying the door leaf clear of the effective opening width.
- To aid unrestricted pedestrian flow and movement, the number of internal doors used should, wherever possible, be kept to a minimum.

- Doors to self-contained wheelchair accessible changing areas, toilets and cubicles in sports wheelchair zones should have a clear opening width of minimum 1000mm; and where the sports facility will potentially be used for wheelchair tennis activities, door width should be increased to 1200mm to avoid the need to transfer from a sports chair to a day chair.⁵ Doors should be outwardly opening and fitted with contrasting horizontal closing bars (set within the range 800mm to 1050mm above floor level; 900mm preferred).
- To make them easier to negotiate, double doors should incorporate a double swing action rather than an interlocking arrangement, unless power operated e.g. using push pad device.
- Except where privacy is required, all doors should be designed to include visibility glazing. Vision panels should provide a minimum zone of visibility between 500mm and 1500mm above floor level.
- For safety reasons, doors should not swing out directly into corridors and passageways. Where outward swing is required or unavoidable e.g. on fire escape routes, doors should be recessed where possible, or protected by guardrails that are clearly distinguishable and lead people away from the door swing. **Note:** guardrails are not required to doors leading out of sports halls into corridors. Provide associated signage to warn of outward door swing.
- Direction of door swing along circulation routes should be consistent.
- Design and installation of doors should ensure that the maximum force required to open doors is as illustrated in Figure 4 of this guide: Door Swing Opening Force Requirements.

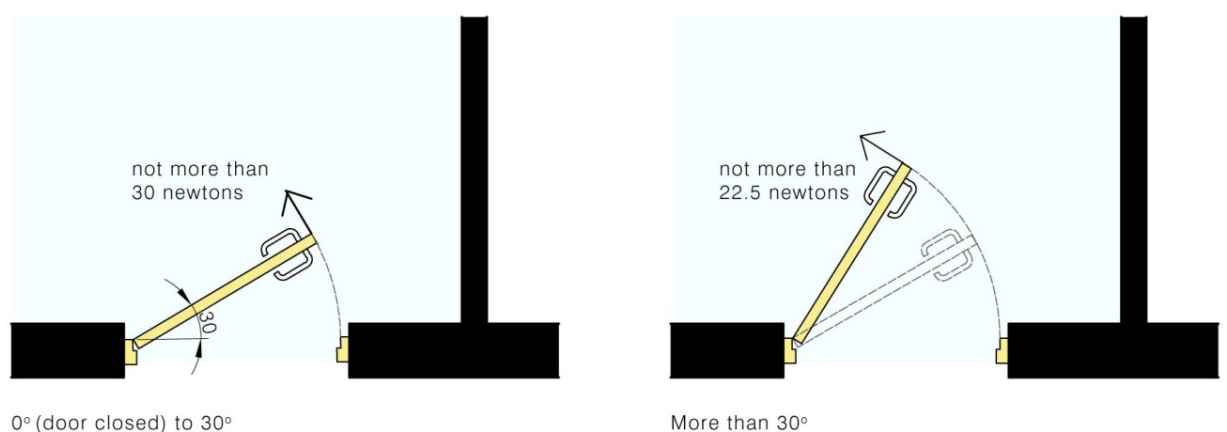

Figure 4 - Door Swing Opening Force Requirements

⁵ For internal doors in sports pavilions see Sports Pavilions Guidance Notes available from Disability Sport NI.

- A space of at least 300mm should be provided between the leading edge of the door and a return wall on the pull side (unless the door is opened by automatic controls).
- Doors that are power operated or automatic will assist a broad range of people, including wheelchair users, assistance dog owners and older people and should be provided where practicable in sports facilities.
- Where provided, automatic doors should be fitted with safety sensors i.e. controlled by a passive infrared system located in an appropriate position, which is sensitive to children and to people who are seated and can sense someone who is standing.
- Door opening furniture with a lever action and closed end, at a comfortable height for wheelchair and ambulant users, should be used to enable doors to be opened one handed.
- The use of locks/latches comprising a lever action, or extended grip thumb-turn, to assist people with reduced dexterity should be provided.
- Do not fit 'Pull' handles on the 'Push' side of non-latch bolt doors that are only capable of swinging in one direction, as this may cause confusion and result in congestion.
- To assist people who are partially sighted, door furniture should contrast visually with the surface of the door.
- Wherever possible, electro-magnetic hold back controls to fire doors, which only close when the fire alarm is activated, should be provided.
- See Section 4.11 of this guide: Visual Contrast.



Internal doors to sports hall (Foyle Arena, Derry-Londonderry); and wide leaf internal door to inclusive toilet area (Omagh Leisure Complex)

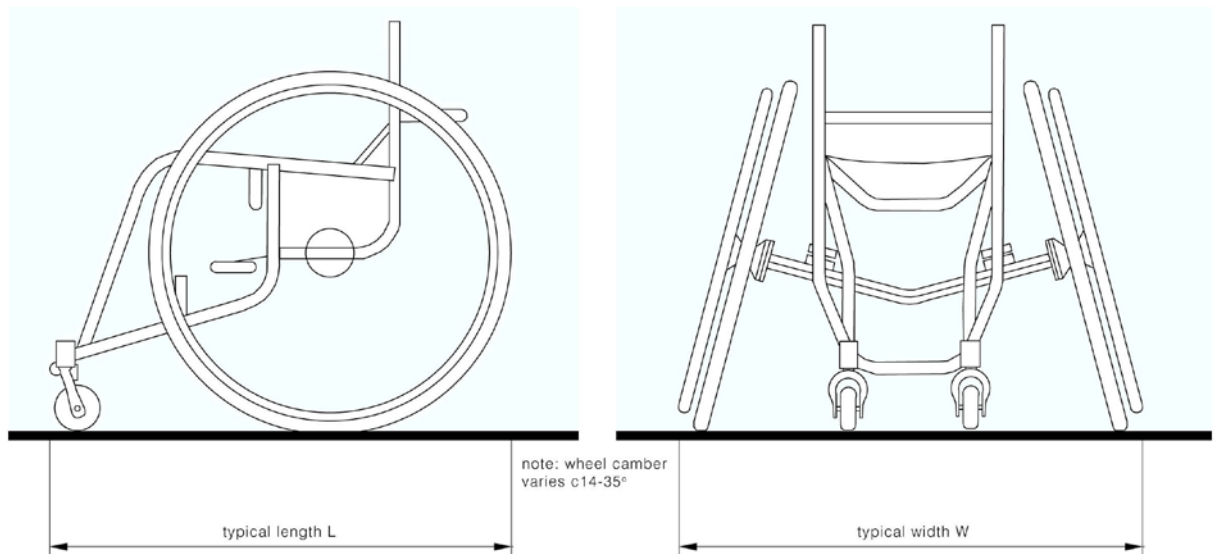

Figure 5 - Sports Wheelchair



Guidance Signpost

- ▶ Stairs, ramps, guarding and protection from impact. Building Regulations (Northern Ireland) 2012 Guidance: Technical Booklet H. **Paragraphs 7.1 - 7.5**, p.43.
- ▶ BS 8300:2009 +A1:2010. **Paragraph 6.4.3** Vision Panels, p.38-39 & **Paragraph 6.4.4** Glass Doors, p.40.
- ▶ BS 8300:2009 +A1:2010. **Paragraph 6.5 - 6.5.5** Door fittings, p.40-45.
- ▶ Access to and use of buildings. Building Regulations (Northern Ireland) 2012 Guidance: Technical Booklet R. **Paragraph 3.12**, p.22.
- ▶ Access to and use of buildings. Building Regulations (Northern Ireland) 2012 Guidance: Technical Booklet R. **Paragraphs 4.13 & 4.14 & Table 4.1**, p.29.
- ▶ Access to and use of buildings. Building Regulations (Northern Ireland) 2012 Guidance: Technical Booklet R. **Paragraph 5.44(g)**, p.47 & **Diagram 5.8**, p.48.
- ▶ Automatic Door Systems. Specifiers' Handbooks for Inclusive Design. Centre for Accessible Environments.
- ▶ Architectural Ironmongery. Specifiers' Handbooks for Inclusive Design. Centre for Accessible Environments.
- ▶ CSN EN 16005. Power operated pedestrian doorsets - Safety in use - Requirements and test methods. 2012.

3.3 Vertical Circulation

3.3.1 Passenger Lifts

Overview

To ensure free and unrestricted access to all areas on all floors of sports facilities, one or more passenger lifts must be provided in all facilities with more than one storey. **Note:** it is not ideal to have the main playing surface at a level other than entrance level, due to logistics when holding disability competitions e.g. manoeuvring equipment, numbers of competitors with disabilities who will be using the facilities etc.

3.3.1.1 Location of lifts

Recommended Standards

- Lifts should be located close to the entrance, reception area and main circulation routes.

3.3.1.2 Lift car specification

Sport Facility Type	Door Width into Lift (minimum dimensions)	Lift Car (minimum dimensions)	No. of Lifts
Sports Pavilions	See Sports Pavilions Guidance Notes available from Disability Sport NI		
Boxing Facilities	See Boxing Facilities Guidance Notes available from Disability Sport NI		
Fitness Suites (including exercise studios)	800mm	1100mm wide by 1400mm deep	1
Swimming Pool (with pool/s and associated pool facilities only)	800mm	1100mm wide by 1400mm deep	1
Sports Facilities (with four courts or less)	1100mm*	2000mm wide by 1400mm deep	1
Large Sports Facilities (with more than four courts, or facility with courts and swimming pool/s)	1100mm*	2000mm wide by 1400mm deep	2
Stadia: See Disability Sport NI Guide 3: Accessible Sports Stadia Design Guidelines (2016 Edition)			

Table 4 - Recommended Number, Size and Dimensions of Lifts

* Except to lifts serving tennis wheelchair activities; whereby minimum lift door width should be increased to 1200mm.

Lift Dimensions	Users Accommodated
1100mm wide by 1400mm deep	One wheelchair user (in manual or electrically powered wheelchair) plus two other people. Not large enough for sports wheelchair
2000mm wide by 1400mm deep	One wheelchair user in sports wheelchair plus several other people OR three people in sports wheelchairs OR person using a mobility scooter

Table 5 - Users Accommodated in Lifts

Note: lifts which have opposite doors enable wheelchair users and sports wheelchair users to exit without turning or reversing.

Recommended Standards

- Lift car size and orientation should be based on Tables 4 and 5 of this guide: Recommended Number, Size and Dimensions of Lifts; and Users Accommodated in Lifts.
- Floor plan layout may dictate that lifts have opposite or perpendicular door configurations on exit. If so, clear audible warning in advance of opening is recommended to inform passengers that doors will be opening behind or to the side.
- Lifts in a bank of lifts to have audible indication at each floor to denote arrival, to help people who are blind or partially sighted to identify which lift to use.
- At each floor level there should be:
 - A clear space of at least 1500mm by 1500mm to ensure adequate manoeuvring space for wheelchair users. Where feasible 2000mm by 2000mm should be provided.
 - Audible announcements to indicate arrival of lift, floor level and direction of travel should be provided to aid people who are blind or partially sighted.
 - A clear visual display indicating the level reached by the lift should be provided inside and outside the lift car, to aid people who are deaf, have a hearing loss or tinnitus.
 - A clearly visible sign opposite and adjacent to the lift with raised embossed numbers/letters indicating the floor level should be provided.

- Landing 'call' buttons should:
 - Be positioned between 900mm and 1100mm above the floor level of the landing and not less than 500mm from any return wall.
 - Have suitable raised tactile numbers/symbols and Braille to indicate function.
 - Be clearly distinguishable through suitable visual contrast.
- The provision of 'fire protected' lifts i.e. evacuation lifts should be considered based on an assessment of the perceived risk as part of the overall fire evacuation strategy. Key to this assessment will be consideration of likely occupancy levels and the nature of occupancy (e.g. likely use of the facility by groups of wheelchair users or other people with mobility difficulties).
- Lift doors should contrast visually with the adjacent landing, and internal car, wall surfaces.
- Internal control buttons should:
 - Be positioned between 900mm and 1200mm above floor level and not less than 400mm from any return wall.
 - Have suitable raised tactile numbers/symbols and Braille to indicate function.
 - Be clearly distinguishable through suitable visual contrast.
- There should be a minimum nine second time delay to the lift door closing mechanism. This will assist older people, people who are blind or partially sighted including assistance dog owners and people with mobility difficulties when approaching and entering/exiting the lift.
- The lift should have an emergency communication system which gives audible and visual indication that the alarm has been raised and received.
- Ensure accurate 'levelling' between the floor of the lift and landing level at each storey as some wheelchair users will find even a small difference in level difficult to negotiate.
- The provision of a duplicate set of controls on the opposite side of the lift car should be provided in larger lifts i.e. 2000mm by 1400mm or larger.
- The floor of the lift should be slip resistant and should not be dark in colour.
- A handrail should be provided along at least one side of the lift car. The top surface of the handrail should be not less than 875mm or not more than 925mm above the floor of the lift.
- Where a lift has only one door, the provision of a mirror on the wall of the car opposite the door is required to aid navigation by wheelchair users. The mirror should be no lower than 900mm from the lift floor.
- Areas of glass in lifts, including mirrors, should be identifiable to people who are blind or partially sighted.

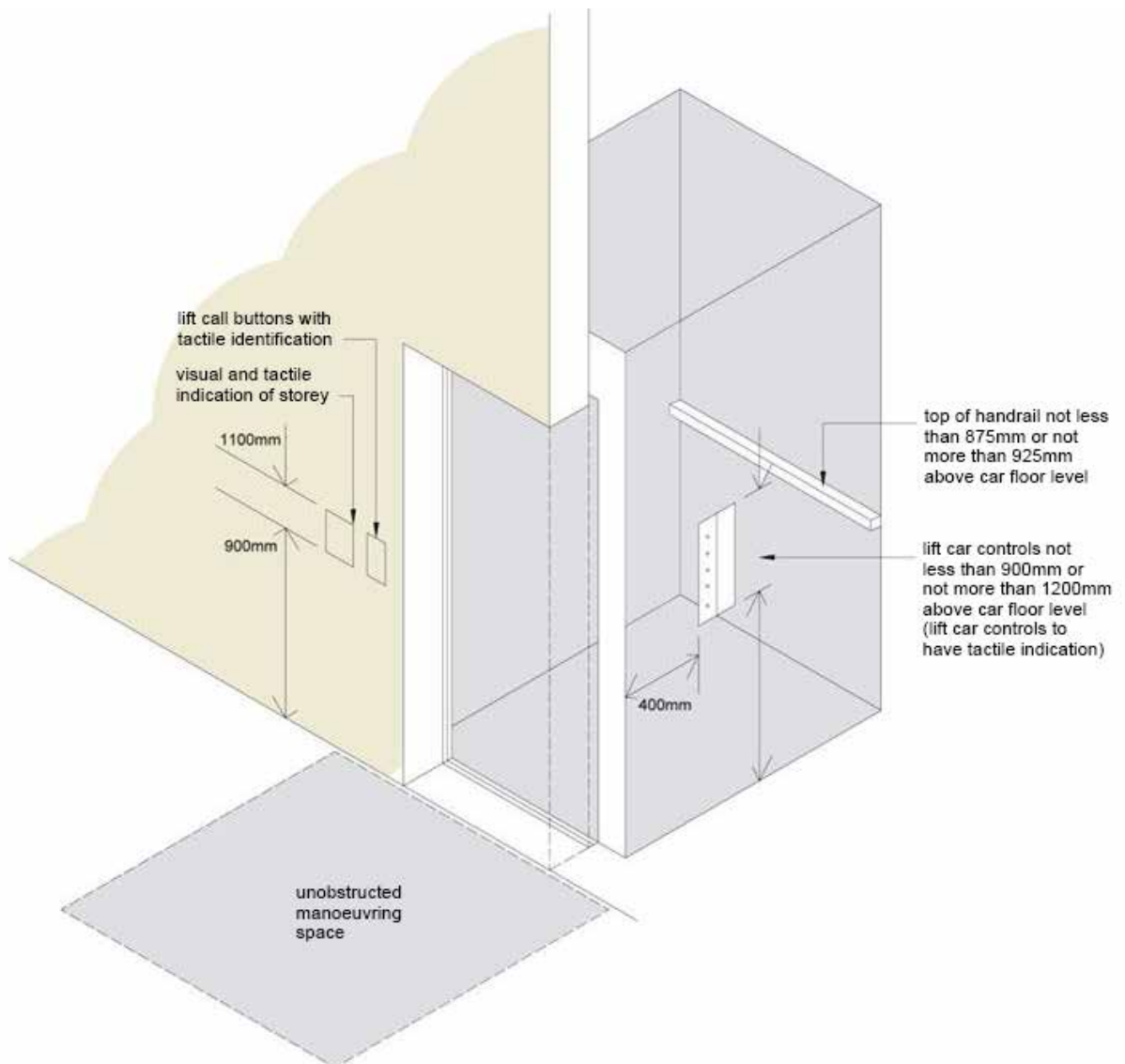

Figure 6 - Passenger Lift Car Fit-out

3.3.1.3 Platform lifts, stair lifts and enclosed vertical lifting platforms

Overview

Although the provision of vertical access using short-rise platform lifts and stair lifts may meet the requirements of Part R of the Building Regulations, these lifting devices are not regarded as providing a reasonable or acceptable means of vertical access to new or refurbished sports facilities for people with disabilities. However, given the space constraints in some existing buildings it may not always be possible in the refurbishment of existing sports facilities to provide an alternative means of vertical access. Enclosed vertical lifting platforms may be acceptable in exceptional site specific areas.

Recommended Standards

- Where it can be demonstrated that full passenger lift standard cannot be achieved in exceptional site specific areas of refurbished or existing sports facilities, enclosed vertical lifting platform provision used to provide vertical access should have:
 - A fully enclosed car.
 - Dimensions capable of accommodating a minimum of one wheelchair user and companion.
 - No restrictions in terms of access or management e.g. assisted or restricted key access is not acceptable.
 - Accessibility features such as visual and audible alert, tactile call and internal buttons, including Braille.



Guidance Signpost

- ▶ BS EN 81-70:2003. Safety rules for the construction and installation of lifts. Particular applications for passenger and goods passenger lifts. Accessibility to lifts for persons including persons with disability.
- ▶ BS EN 81-2:1998 +A3:2009. Safety rules for the construction and installation of lifts. Hydraulic lifts.
- ▶ BS EN 81-1:1998 +A3:2009. Safety rules for the construction and installation of lifts. Electric lifts.

3.3.1.4 Stairs

Overview

Stairs should be designed to make them easier and safer to use by ambulant disabled people and people who are blind or partially sighted.

Recommended Standards

- The maximum number of risers in a flight should be twelve.
- The provision of flights of less than three risers should be avoided.
- A landing should be provided at the bottom and top of each flight of stairs.
- Landing width should be at least that of the stair width.
- The unobstructed landing length of each landing should be not less than 1200mm clear of any door swing onto it.
- There should be clear unobstructed stair width of at least 1200mm.
- The rise of stairs should be in the range 150mm to 170mm.
- The going of stairs should be in the range of 250mm to 300mm.
- Stair risers within a flight or series of flights should be uniform, as irregular risers can be confusing for people who are blind or partially sighted.
- Surface finish should be slip resistant.
- A stair nosing should extend the full width of the flight and be made of slip resistant material. A stair nosing should wrap around the step so that it extends 55mm on the tread and 55mm on the riser.
- Stair nosings should be distinguishable from the remainder of the step e.g. through suitable permanent visual contrast.

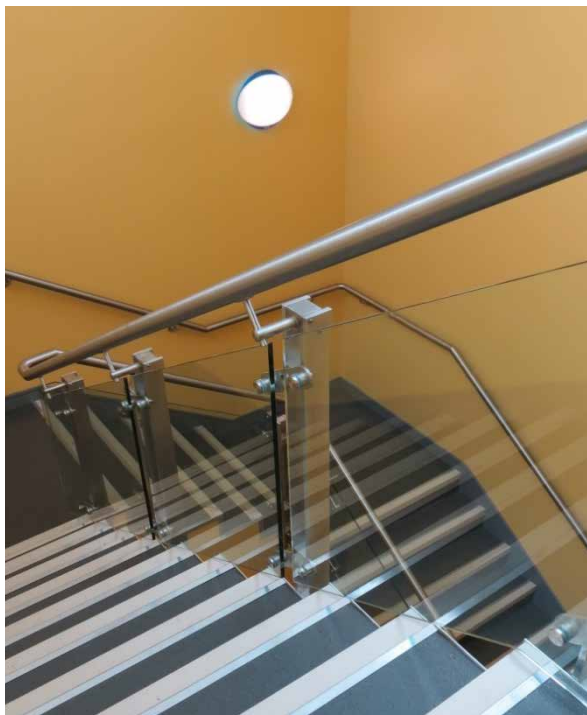

Staircases at Foyle Arena, Derry-Londonderry and Newry Leisure Centre



Guidance Signpost

- ▶ Stairs, ramps, guarding and protection from impact. Building Regulations (Northern Ireland) 2012 Guidance: Technical Booklet H. **Paragraphs 3.4 - 3.11**, p.21-24 and **Paragraphs 3.30 - 3.43**, p.30-32.

3.3.1.5 Helical and spiral stairs

Note: flights of stairs of a helical or spiral design are not regarded as providing a reasonable means of access. This is because many people with disabilities find stairs of this design difficult or impossible to use. They are particularly hazardous for assistance dog owners, given that either the dog or the owner has to descend on the narrow side. They are not acceptable in new or refurbished sports facilities.

3.3.1.6 Internal ramps

Overview

It is not envisaged that internal ramps will be appropriate in new sports facilities or that those undergoing refurbishment will include internal ramps. Where circulation ramps are unavoidable they should be designed in accordance with good practice guidance.

Recommended Standards

- Avoid using 'split-level' areas in sports facilities.
- Even a gentle slope or a slight change in level can be disconcerting or present a tripping hazard, therefore should be clearly signed and identified at floor level to warn all users, including people who are partially sighted.



Guidance Signpost

- ▶ BS 8300:2009 +A1:2010. **Paragraphs 8.2 - 8.2.4** Internal ramps, p.54-55.
- ▶ BS 8300: 2009 +A1:2010. **Paragraphs 5.8.2 - 5.8.4** Gradient, Ramp widths, Landings, p.23-24.
- ▶ Stairs, ramps, guarding and protection from impact. Building Regulations (Northern Ireland) 2012 Guidance: Technical Booklet H. **Paragraphs 4.14 - 4.22**, p.36-38.

3.4 Handrails and Handholds

Overview

The majority of people with disabilities are ambulant disabled people. The provision of well designed handrails and handholds in sports facilities will assist all users, to ascend and descend stairs and gangways, including ambulant disabled people. People with a range of disabilities will benefit too e.g. people who are blind or partially sighted and people with hidden disabilities, such as epilepsy and heart conditions. Handholds will assist all spectators in steep viewing areas.

3.4.1 Handrails

Recommended Standards

- Handrails should be provided on each side of steps, stairs and ramps.
- The surface of handrails should be distinguishable from the background against which they are seen e.g. through suitable visual contrast.
- A handrail should be at a height of between 900mm and 1000mm from the pitch line and between 900mm and 1100mm from the surface of the landing.
- A handrail should extend not less than 300mm horizontally beyond the top and bottom landings of a stair flight or ramp and should be terminated in a way that will reduce the risk of clothing being caught e.g. by terminating the handrail at floor or ground level.
- Handrails are required in addition to safety guardrails, therefore provision of both may be required on some steps and stairways.
- If steps and stairways consist of more than two flights connected by a landing the handrail should run continuously across the landing area.
- Handrails should be oval or circular in shape:
 - A circular handrail should have a diameter in the range 32mm to 50mm.
 - An oval handrail should have dimensions of 50mm wide and 39mm deep with a radius of at least 15mm.
- Handrails should be easy and comfortable to grip.
- There should be a clearance of between 50mm and 75mm between a handrail and any adjacent wall or obstacle.
- Handrails should be clearly distinguishable from safety barriers/guardrails e.g. using visual contrast.

- To assist people who are blind or partially sighted, tactile markers/cues should be incorporated to the underside of handrails at the top and bottom of steps and stairways. This can be achieved by placing tactile markers/cues on the underside of each handrail, as described below:
 - Three steps from top/bottom of stairs: three tactile markers placed on underside of handrail;
 - Two steps from top/bottom: two tactile markers placed on underside of handrail;
 - One step from top/bottom: one tactile marker placed on underside of handrail. **Note:** it is essential that tactile markers are regularly inspected and maintained.

Additional Considerations

- Handrails should not be excessively cold to the touch.



Guidance Signpost

- ▶ BS 8300:2009 +A1:2010. **Paragraphs 5.10.1 - 5.10.5** Handrail Provision, p.28-30.

3.4.2 Handholds



Guidance Signpost

- ▶ For sports facilities where spectator viewing is provided, see Disability Sport NI Guide 3: Accessible Sports Stadia Design Guidelines (2016 Edition). **Section 3.8.2** Handholds, p.36.

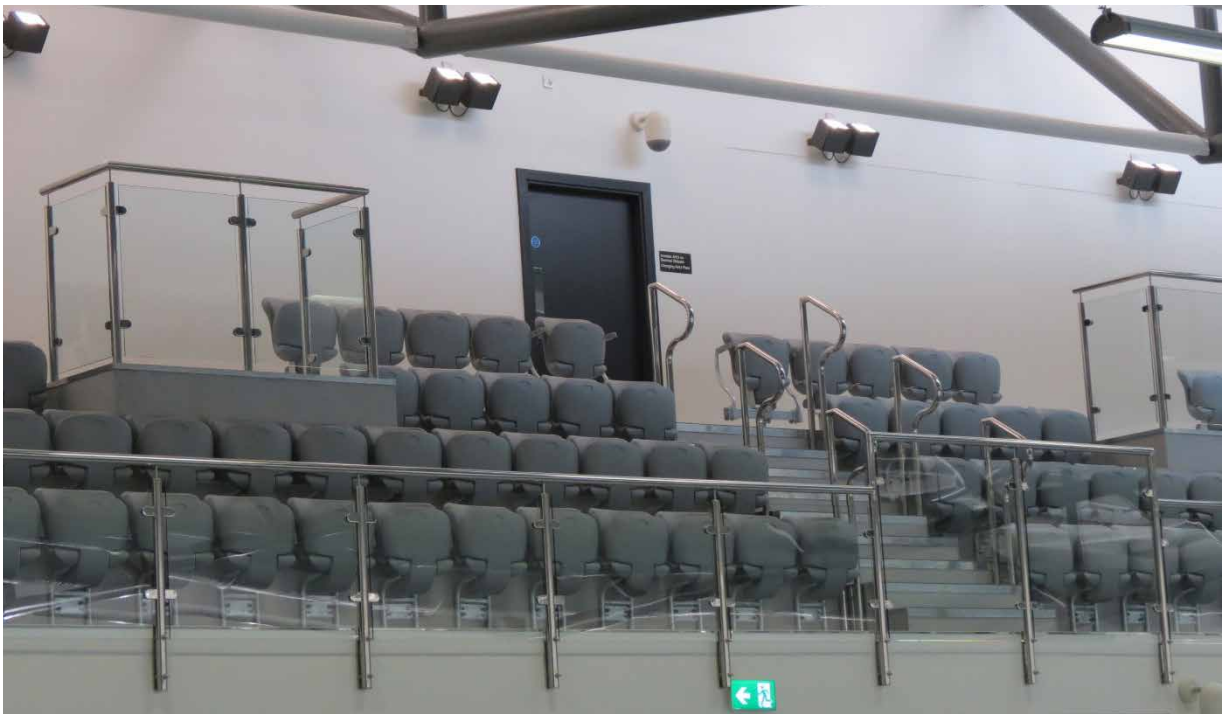

Viewing area with handholds on gangways, accessible seat provisions and wheelchair user spaces (Newry Leisure Centre)

4 Accessible Sports Facilities and Use Of Facilities

4.1 Sanitary Provision

Overview

The lack of good quality toilet, changing and shower facilities in many existing sports facilities presents a significant barrier to the participation of people with disabilities in sport. The establishment of sports centres and facilities which provide good quality accessible facilities of a more inclusive design and which also offer a greater degree of choice will undoubtedly be more attractive to people with disabilities.

Suitable and sufficient toilet provision should be provided for people with disabilities in sports facilities. This should include provision for independent use and provision for assisted use. Many people with disabilities do not require all of the facilities provided by a wheelchair accessible WC. The recommendations below focus on the development of toilet amenities of a more inclusive design, which can benefit people with a wide range of abilities, combined with the provision of additional stand-alone accessible units.

A Changing Places (CP) toilet facility is a room for use by people with complex and multiple disabilities which includes an adult sized changing bench and hoist, in addition to a shower and toilet. Any larger building where the public has access in numbers or where visitors might be expected to spend longer periods of time is a suitable venue for a Changing Places toilet facility.

4.1.1 Design of accessible toilets

4.1.1.1 Inclusive toilet blocks

Overview

Wherever a general block of male/female toilets is provided they should be designed to be inclusive of non-disabled people and people with disabilities.

Recommended Standards

- A wheelchair accessible corner layout WC cubicle for independent use, with minimum dimensions 1500mm by 2200mm.⁶ See Figure 8 of this guide for fit-out: Unisex Wheelchair Accessible WC. **Note:** this unit will suffice as an 'enlarged WC compartment' where a male or female block contains four or more cubicles.
- At least one accessible urinal should be at a height suitable for wheelchair users in each male toilet block.
- At least one accessible wash hand basin should be at a height suitable for both ambulant disabled people and wheelchair users in each male and female toilet block.
- See Figure 7 of this guide: Ambulant WC Cubicle; Urinals and Wash hand basins accessible to wheelchair users and ambulant disabled people.
- An ambulant accessible toilet cubicle, with outward opening door swing in each male and female toilet block.
- Contrasting grabrails fitted within all accessible cubicles in accordance with standards, including horizontal rails set at 680mm above floor level.

Note: lowered wash hand basins and urinals will also be beneficial for children and people of small stature.



Wheelchair accessible WC cubicle within inclusive toilet block (Bangor Aurora Aquatic and Leisure Complex)

Additional Considerations

- At least one ambulant accessible urinal in each male toilet block. See Figure 7 of this guide: Ambulant WC Cubicle; Urinals and Wash hand basins accessible to wheelchair users and ambulant disabled people.
- At least one ambulant accessible wash hand basin in each male and female toilet block. See Figure 7 of this guide: Ambulant WC Cubicle; Urinals and Wash hand basins accessible to wheelchair users and ambulant disabled people.
- One lowered WC pan for use by children should be considered within male/female blocks of toilets. Height should be 380mm.

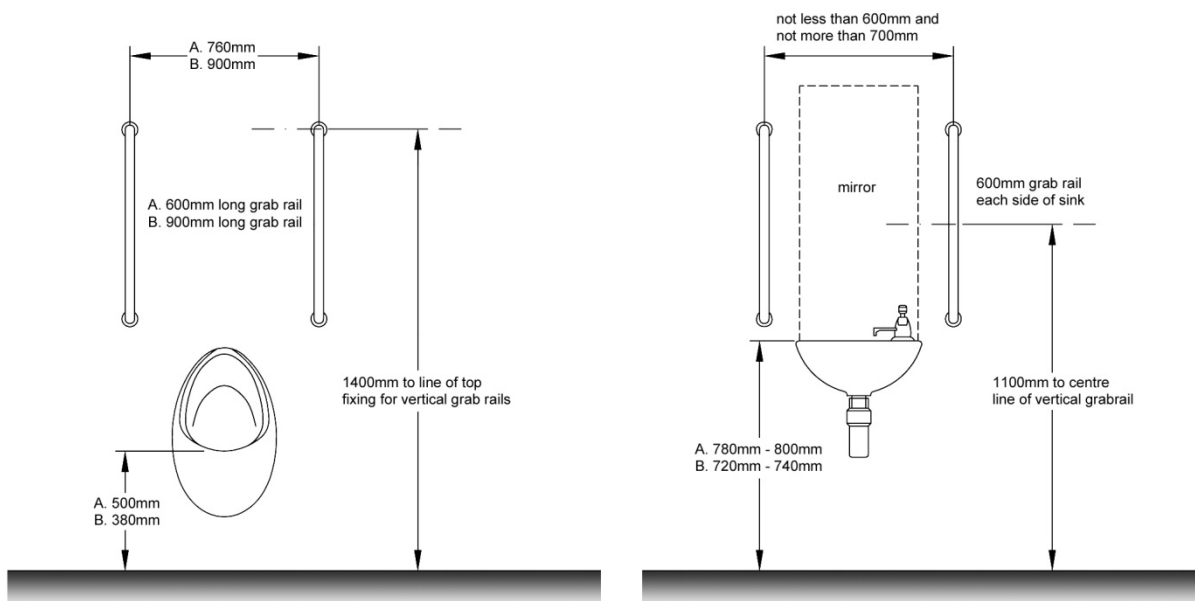
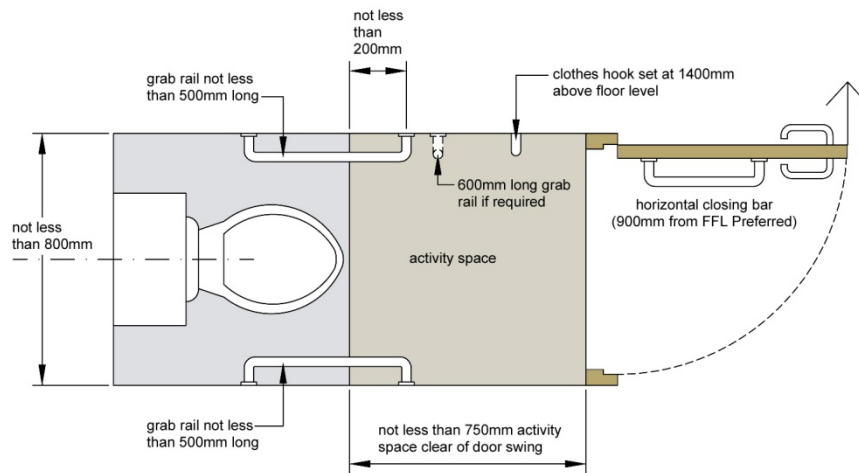

A. Suitable for ambulant disabled people only
 B. Suitable for both ambulant disabled people and wheelchair users

Figure 7 - Ambulant WC Cubicle; Urinals and Wash hand basins accessible to wheelchair users and ambulant disabled people



Guidance Signpost

- ▶ BS 8300:2009 +A1:2010. **Paragraph 12.6.3.3** WC compartment accessible by ambulant disabled people, p.145.



Lowered wash hand basin and urinal provision, including contrasting grabrails, within inclusive toilet areas (Foyle Arena, Derry-Londonderry)



Ambulant accessible WC cubicle within inclusive toilet area (Foyle Arena, Derry-Londonderry)

4.1.1.2 Unisex wheelchair accessible WC unit

Overview

A self-contained unisex wheelchair accessible WC for independent use should be located outside of, but as close as possible to each general male/female block of toilets in all sports facilities. See Figure 8 of this guide: Unisex Wheelchair Accessible WC.

Recommended Standards

- A self-contained unisex wheelchair accessible corner layout WC, in addition to the provisions within inclusive toilet blocks.
- Minimum dimensions 1500mm wide by 2200mm long.
- Contrasting grabrails fitted in accordance with standards, including horizontal and drop-down rails set at 680mm above floor level.
- Where there is more than one corner layout accessible WC provide a choice of left and right hand transfer in corner layout wheelchair accessible WCs and signage to indicate same.
- Horizontal travel distance to a wheelchair accessible WC should be maximum 40m.



Guidance Signpost

- ▶ BS 8300:2009 +A1:2010. **Paragraph 12.6.3.1** Wheelchair accessible corner WC, p.138-143.

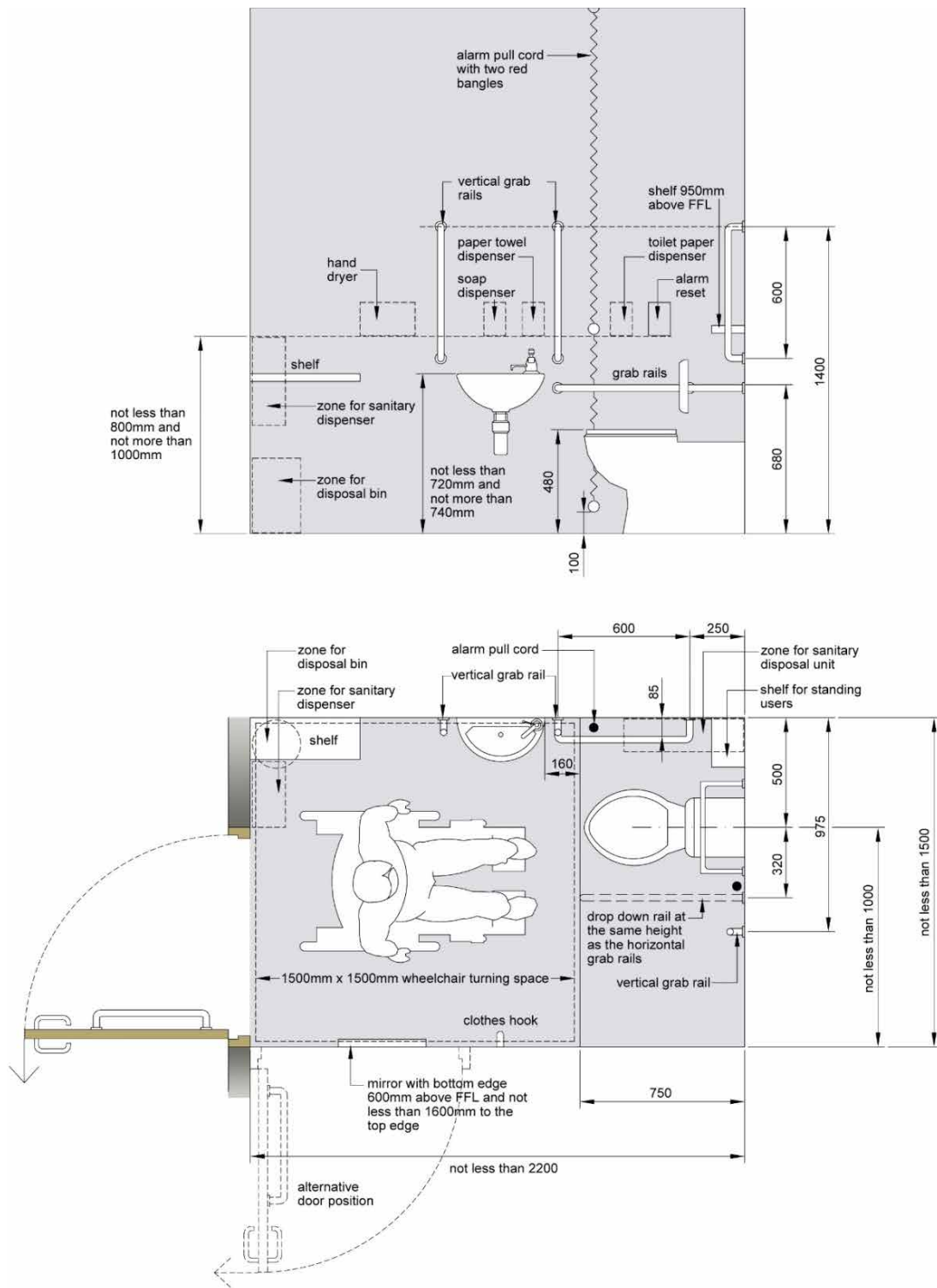

Figure 8 - Unisex Wheelchair Accessible WC

4.1.1.3 Unisex accessible peninsular WC for assisted use

Overview

In addition to the requirement for corner layout wheelchair accessible WCs for independent use, peninsular WC units for assisted use provided in sports facilities will benefit people with disabilities who require carer or companion assistance in order to use toilet facilities. A peninsular layout WC should not be provided as a substitute for two separate unisex accessible WCs with handed corner layouts, but as an additional facility. See Figure 9 of this guide: Unisex Accessible Peninsular WC for Assisted Use.

Recommended standards

- This WC unit should be located outside of, but as close as possible to, each general male/female block of toilets.

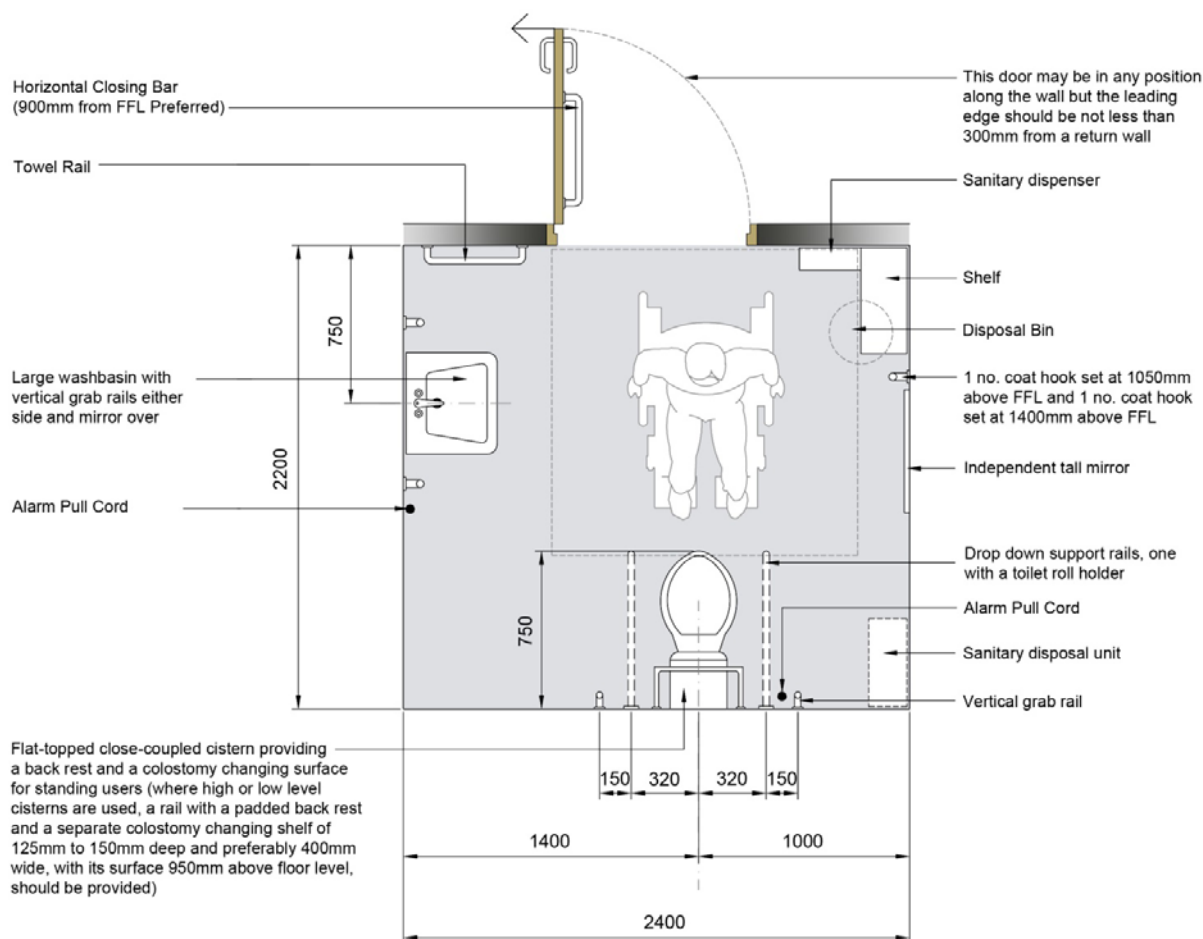

Figure 9 - Unisex Accessible Peninsular WC for Assisted Use



Guidance Signpost

- ▶ BS 8300:2009 +A1:2010. **Paragraph 12.6.3.2** Unisex accessible peninsular WC for assisted use, p.143-144.

Additional Considerations

- Hand dryers positioned adjacent to basins, not on the opposite wall.
- Tactile surface surround to sensor operated taps/soap dispensers.
- WC pans wall-mounted, as opposed to pedestal style.
- Ensure contrast is provided to mirrors and avoid excessive glare.



Guidance Signpost

- ▶ Access to and use of buildings. Building Regulations (Northern Ireland) 2012 Guidance: Technical Booklet R. **Paragraphs 6.1, 6.2, 6.8, 6.11, 6.12, 6.16, 6.18, 6.19, 6.21**, p.50-57.

4.2 Changing Places Toilet Facilities

Overview

In large sport and leisure complexes consideration should be given to the addition of a Changing Places toilet facility. Changing Places toilet facilities require extended space to accommodate people with disabilities, who may often have large complex wheelchairs with elevated leg rests, a reclining facility or integral oxygen cylinders and space to fit slings for use with a hoist. It also needs to be possible for a wheelchair to be parked within the facility when not in use without compromising the safe access and use of the equipment. As Changing Places toilet facilities are not designed for the use of independent wheelchair users, or as baby changing facilities, it is desirable for facility providers to indicate the location of the nearest unisex accessible WC and the nearest baby changing facility.



Guidance Signpost

- ▶ BS 8300:2009 +A1:2010. **Paragraph 12.7** Changing Places sanitary accommodation, p.151-153.
- ▶ Changing Places: the practical guide. Changing Places Consortium. <http://theaccessofficer.files.wordpress.com/2013/11/changing-places-a-practical-guide.pdf>
- ▶ <http://www.changing-places.org>



Height adjustable adult-sized changing bench (Newry Leisure Centre)

4.3 Baby Changing Facilities

Overview

People with disabilities require quick and easy access to designated toilet facilities. This is not always possible if facilities are designed as dual purpose i.e. used also for baby changing/feeding. Baby changing can require additional time than general toileting. Toilet facilities, therefore may not be available when people with disabilities require to use them. **Note:** the child or the parent may have a disability.

Recommended Standards

- Baby and child changing should be accessible and separate to any Changing Places toilet facility or accessible toilet facilities.
- A height adjustable bench suitable for babies and children should be installed, to solid blockwork walls only.

Additional Considerations

- Lowered WC pan for use by children in accessible baby changing units (additional space allowance should be considered to accommodate the extra WC provision). Height should be maximum 380mm.

4.4 Accessible Changing and Showering

Overview

In sports facilities, changing and shower areas should be of an inclusive design so that they can accommodate people with a range of abilities and provide a degree of choice. A combination of inclusive wheelchair accessible incorporated provision and self-contained unisex accessible rooms should be made available, as outlined in Sections 4.4.1 and 4.4.2 of this guide.⁷



Guidance Signpost

- ▶ Access to and use of buildings. Building Regulations (Northern Ireland) 2012 Guidance: Technical Booklet R. **Paragraph 6.26**, p.58.

4.4.1 Inclusive changing area

Recommended Standards

- Changing areas should be designed to be inclusive and have at least one wheelchair accessible incorporated changing provision. See Figure 10 of this guide: Inclusive Changing Area (with wheelchair accessible incorporated provision).
- Doors into inclusive changing areas should meet the minimum door dimensions specified in Table 3 of this guide: Minimum Internal Door Leaf Width and should ideally be power operated.
- Where changing cubicles are provided in inclusive changing areas, at least one wheelchair accessible cubicle should be provided. In larger facilities, provide at least one wheelchair accessible cubicle or 8% of the total number of cubicles, whichever is the greatest. Each cubicle should have minimum dimensions of 2000mm by 2000mm and meet minimum door dimensions specified in Table 3 of this guide: Minimum Internal Door Leaf Width.

⁷ For accessible changing and shower areas in sports pavilions see Sports Pavilions Guidance Notes available from Disability Sport NI.

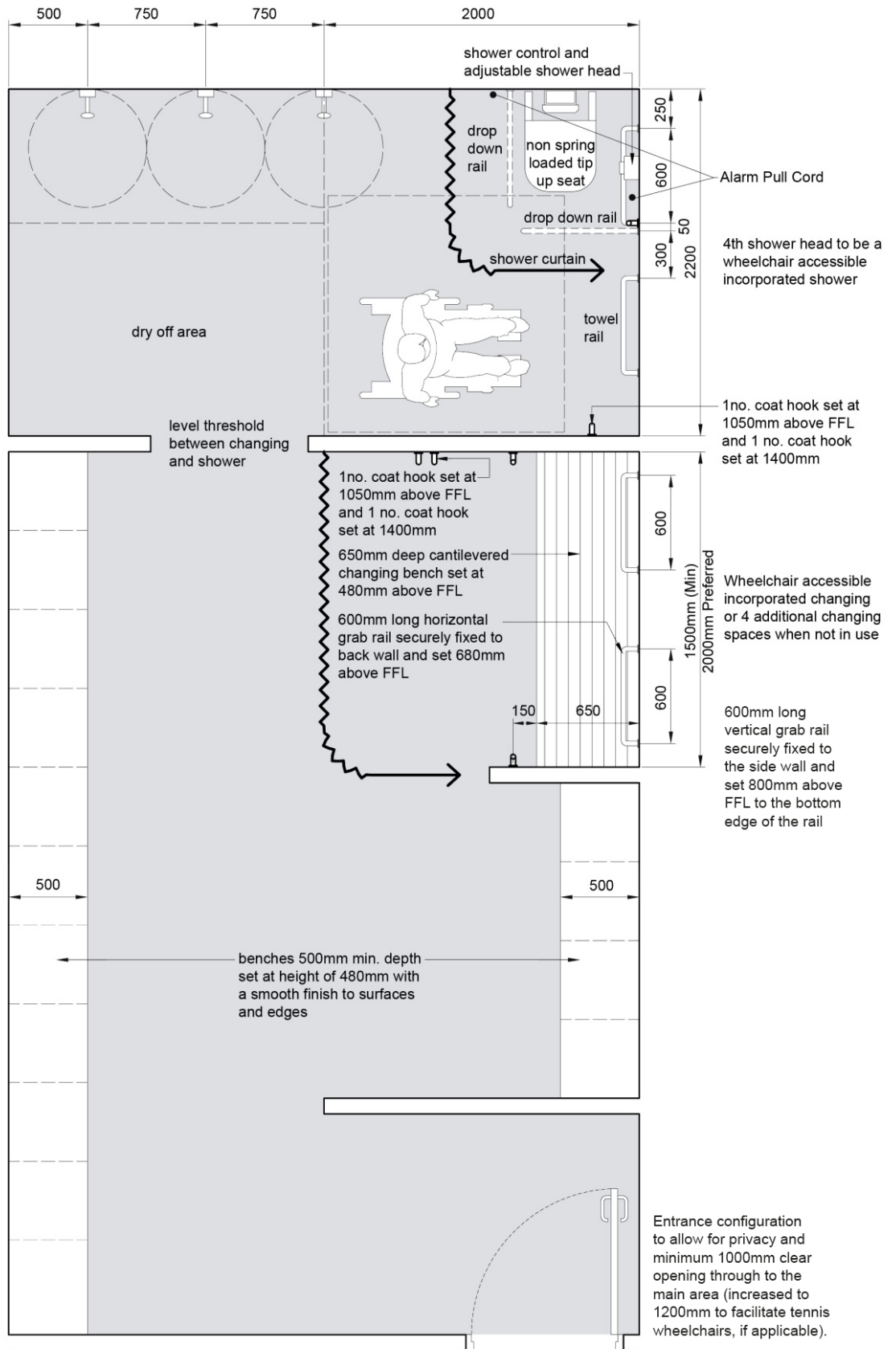

Figure 10 - Inclusive Changing Area (with wheelchair accessible incorporated provisions)



Wheelchair accessible incorporated changing provision within inclusive changing area (Foyle Arena, Derry-Londonderry)

4.4.1.1 Shower provision

Recommended Standards

- Where showers are provided, an inclusive changing area should have at least one wheelchair accessible incorporated shower provision, fitted with a tip-up seat and appropriate grabrails. See Figure 10 of this guide: Inclusive Changing Area (with wheelchair accessible incorporated provision). In larger sports facilities a minimum of 4 or 8% of total showers, whichever is the greatest, is recommended. **Note:** this is in addition to the self-contained unisex provision outlined in Section 4.4.2 of this guide: Self-contained unisex accessible changing/shower/WC rooms.
- Where a wheelchair accessible incorporated shower provision comprises a cubicle(s), the minimum door dimensions specified in Table 3 of this guide: Minimum Internal Door Leaf Width should be achieved.



Wheelchair accessible incorporated shower provision within inclusive changing area (Newry Leisure Centre)

4.4.2 Self-contained unisex accessible changing/shower/WC rooms

In sports facilities, self-contained unisex accessible changing/shower/WC rooms are necessary to accommodate people who prefer more privacy, or who may require the assistance of someone of the opposite gender.

Recommended Standards

- At least one self-contained unisex accessible changing/shower/WC room. See Figure 11 of this guide: Self-contained Unisex Accessible Changing/Shower/WC Room. **Note:** this is in addition to the wheelchair accessible incorporated changing and shower provision within inclusive changing areas outlined in Section 4.4.1 of this guide: Inclusive changing area.
- Where single sex male and female changing and shower areas are provided, unisex accessible changing/shower/WC rooms must be located outside of, but close to, the male and female changing and shower areas.
- Where staff facilities are provided, at least one self-contained unisex wheelchair accessible changing/shower/WC room should be available for staff use. However, where it is impracticable to facilitate this, a wheelchair accessible incorporated provision should be included.⁸ See Figure 10 of this guide: Inclusive Changing Area (with wheelchair accessible incorporated provision).
- Doors to self-contained unisex accessible changing/shower/WC rooms should meet the minimum door dimensions specified in Table 3 of this guide: Minimum Internal Door Leaf Width.

⁸ For shower provisions in sports pavilions see Sports Pavilions Guidance Notes available from Disability Sport NI.

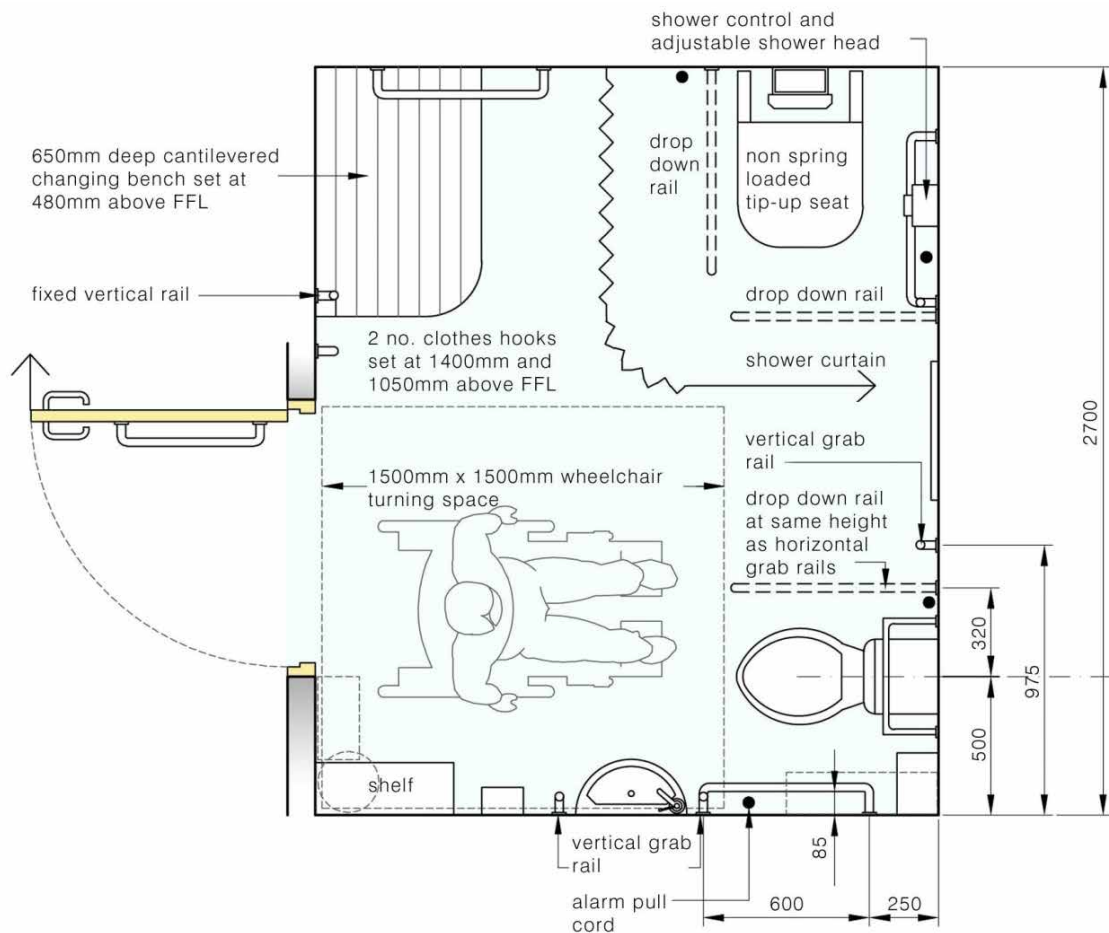

Figure 11 - Self-contained Unisex Accessible Changing/Shower/WC Room

4.4.3 Fit-out of inclusive changing and shower areas

4.4.3.1 General

Recommended Standards

- Toilet provision must be available in close proximity to accessible changing and shower areas. See Section 4.1 of this guide: Sanitary Provision.
- Floor finishes must be slip resistant. See Section 4.12 of this guide: Floor Finishes and Court Markings.
- A minimum 1500mm by 1500mm manoeuvring space is required throughout inclusive changing areas. Where appropriate, this should be increased to a 2000mm by 2000mm clear manoeuvring space to facilitate users of sports wheelchairs.
- There should be a level threshold between changing and shower areas.

4.4.3.2 Showers

Recommended Standards

- Showers must be accessible and easy for all people to use.
- Enough space should be provided to enable transfer from a wheelchair to a tip-up seat. See Figure 10 of this guide: Inclusive Changing Area (with wheelchair accessible incorporated provision).
- Tip-up seats should be 480mm in height.
- Shower controls should be lever operated and located at an accessible height in the range 750mm to 1000mm above floor level.
- Shower heads should be located to ensure adequate water distribution for wheelchair users. There should be a height adjustable shower head in the range 1200mm to 1400mm above floor level and, in self-contained unisex accessible changing/shower/WC rooms, a fixed shower head also.
- Self-propelled waterproof shower chairs should be provided for use in showers and wet areas e.g. this provision enables use in shower zones, at poolside and access/transfer within spa facilities.



Shower/poolside chair

4.4.3.3 Benches

Recommended Standards

- A bench 480mm in height, minimum 1500mm (2000mm preferred) in length and 650mm in depth should be provided within wheelchair accessible incorporated changing provisions and in wheelchair accessible cubicles. Elsewhere within the overall inclusive changing area, benches 480mm in height and minimum 500mm in depth should be provided.
- In self-contained unisex accessible changing/shower/WC rooms, a bench 480mm in height and 650mm in depth should be provided.

4.4.3.4 Coat hooks

Recommended Standards

- 1 no. hook 1050mm high and 1 no. hook at 1400mm high is required in self-contained unisex accessible changing/shower/WC rooms, within wheelchair accessible incorporated changing and shower provisions, and in wheelchair accessible cubicles.
- Hooks located at 1400mm high and a provision of hooks located at 1050mm high to facilitate children and wheelchair users, in an inclusive changing area. **Note:** to reduce potential risk, hooks at the lower height of 1050mm specify 'flip' hooks i.e. hooks which flip down when required, otherwise resting flush against their backboard/rail.
- Hooks to contrast visually with the surrounding wall or backboard/rail.



Alternate hooks fitted within inclusive team changing room (contrasting hooks and backboards) - Newry Leisure Centre

4.4.3.5 Lockers

Overview

In sports facilities, lockers of varying height will accommodate people with a range of abilities.⁹ Lockers with clear kneespace below will assist wheelchair users, whilst longer length (1200mm) and full height (1800mm) lockers offer limb storage for the benefit of amputees.

Recommended Standards

- Where lockers are provided in sports facilities 10% of lockers should be accessible, including:
 - Provision for lockers set at a height to accommodate wheelchair users, including clear kneespace below (in the range 450mm to 900mm above floor level to the underside; 700mm preferred).
 - Provision for lockers at least 1200mm high to facilitate the storage of mobility aids and artificial limbs etc.
 - Provision for 1800mm full height lockers 400mm in width assist people who use mobility aids such as underarm crutches.
- Sports facilities should have some locker provision available to offer limb storage for the benefit of amputees, regardless of whether lockers are provided generally.
- Any self-contained unisex wheelchair accessible changing/shower/WC room should have a fixed storage system for limb storage for the benefit of amputees outside but immediately adjacent to it e.g. full height 1800mm locker.
- Any wheelchair accessible incorporated changing or shower provision should have a fixed storage system for limb storage for the benefit of amputees immediately adjacent to it e.g. full height 1800mm locker.
- Locks to wheelchair accessible lockers should be located no higher than 1150mm above floor level and be fitted with opening devices that are easy to use one handed by a person of limited dexterity, arthritis or weak grip. Locking devices should be large and clear to assist people with sight loss.
- Lockers should be fitted with large tactile numbers.
- Accessible lockers should be fitted with contrasting symbol signage, to discourage use by non-disabled people.

⁹ For locker provision in sports pavilions see Sports Pavilions Guidance Notes available from Disability Sport NI.



Examples of full height limb lockers and wheelchair accessible lockers at Dunville Park, Belfast and Newry Leisure Centre (lockers on right are fitted with large contrasting tactile numbers and include Braille)



Example of symbol signage used to accessible lockers (Foyle Arena, Derry-Londonderry)

4.4.3.6 Grooming areas

Recommended Standards

- Grooming areas should have at least one hairdryer and mirror accessible to wheelchair users.
- Hairdryer controls should be set at a maximum height of 1100mm above floor level.
- A mirror with bottom edge 600mm above floor level and top edge not less than 1600mm above floor level should be provided.



Grooming area provisions within inclusive village changing area (Newry Leisure Centre)

4.5 Specific Provisions for Pool and Associated Pool Facilities

- There is an expectation that the following provisions will be made to enhance the accessibility of swimming pool and associated spa facilities for a range of user ability:
 - Contrasting ramp or easy steps with contrasting nosings and suitably designed contrasting handrails to access all pools.
 - Hoist provision to access all pools.
 - Self-propelled waterproof poolside chairs, for use between from changing areas and pool/spa facilities.
 - Self-propelled waterproof poolside chairs for use in wet areas e.g. this provision enables use in pool showers, at poolside and access/transfer within spa facilities.
 - Access to and within spa facilities e.g. suitable door and access widths to sauna, steam room and experience showers, adequate turning circle provisions and rest spaces.
 - Contrasting clothes/towel hooks at 1050mm and 1400mm above floor level within ice bath areas.
 - Contrasting nosings to flumes, and contrasting handrails where possible.
 - Accessible controls within spa facilities and clear instructional signage.
 - For further information, see also Section 8.9 of this guide: Sports Specific Access Information - Swimming.



Contrasting step nosings and handrails to spa pool (Newry Leisure Centre)

4.6 Commercial Activities

Overview

Commercial facilities may be available as part of the overall sports facility provisions. For example, refreshment or catering facilities for customers and/or staff. Such areas should be accessible for all.

Recommended Standards



Guidance Signpost

- ▶ BS 8300:2009 +A1:2010. **Paragraph 12.1.3.3** Single height work surface for a kitchenette or refreshment area shared by wheelchair users and people standing, p.109.
- ▶ BS 8300:2009 +A1:2010. **Paragraphs 13.5 - 13.5.3** Refreshment buildings, including public houses, restaurants and cafes, p.169.
- ▶ BS 8300:2009 +A1:2010. **Paragraph 13.9.2** Accessible routes and spaces, p.177.

4.7 Fitness Suites and Fitness Equipment

Overview

Physical access to and from fitness suites within sports facilities will be achieved through the implementation of recommended standards outlined in the relevant sections of this document, however the overall accessibility of fitness suites for people with disabilities can only be achieved if the fitness and conditioning equipment provided is also designed to be inclusive.

Recommended Standards

- To accommodate the access and training needs for a range of disabilities, all fitness suites should provide a range of Cardiovascular and Resistance IFI (Inclusive Fitness Initiative) Accredited equipment. Range of equipment required includes:
 - Cardiovascular Upper Body e.g. upper body ergometer
 - Cardiovascular Lower Body e.g. treadmill and recumbent/recline cycle
 - Cardiovascular Total Body e.g. cross trainer
 - Fixed Lower Body Resistance e.g. leg curl, leg extension and leg press
 - Fixed Upper Body Resistance e.g. chest press, row, shoulder press, lateral pull-down and tricep/bicep curls; or equivalent multi-station

- Free Movement Resistance Small Equipment Pack, which comprises:
 - Neoprene dumbbells - 0.5kg, 1kg, 2kg, 3kg, 4kg pairs
 - Soft grip dumbbells (with handstrap) - 0.5kg, 1kg pairs
 - Pilates bands - light, medium and heavy
 - Resistance tubes - light, medium and heavy
 - Wrist weights - 0.5kg, 1kg pairs
 - Ankle weight - 2kg pair
 - Gym ball stabiliser
 - Air disc
 - Squeeze balls (Pack of 3)
 - Core/stabiliser tube - light, medium and heavy
 - Pilates ring
- Transfer space should be provided around each piece of equipment.



IFI Accredited equipment (Lakeland Forum, Enniskillen)



Guidance Signpost

- ▶ Accessible Sports Facilities, Design Guidance Note. **Section 16** Fitness suite: Screening area, Mirrors, Equipment layout, Stretch area, Rest area, Air conditioning, p.69-70. Sport England Publications, Wetherby. Sport England 2010.
- ▶ http://www.efds.co.uk/assets/000/000/419/D2F_IFI_Fitness_Equipment_Brochure.v1.brochure_original.pdf?1463152930

4.8 Public Telephones

Overview

In sports facilities where public telephones are provided, they should be located close to the reception area and at least one should be located at an accessible height for people with disabilities, fitted with an induction coupler that is identified using symbol signage.¹⁰



Guidance Signpost

- ▶ BS 8300:2009 +A1:2010. **Paragraphs 10.4 - 10.4.3** Public telephones, p.83-85.

4.9 Outlets, Switches and Controls

Overview

In order to facilitate wheelchair users and other people with disabilities the location, type and height of outlets, switches and controls should be in accordance with Building Regulations.¹¹

¹⁰ For public telephones in sports pavilions see Sports Pavilions Guidance Notes available from Disability Sport NI.

¹¹ For outlets, switches and controls in sports pavilions see Sports Pavilions Guidance Notes available from Disability Sport NI.

Recommended Standards

- See Figure 12 of this guide: Outlets, Switches and Controls.
- Where possible, lighting in internal rooms to which the public have access should be motion sensor activated. If use of outlets, switches and controls is unavoidable, they should be designed in accordance with Building Regulations.
- Controls for power operated doors should be located between 750mm and 1000mm above floor level and not less than 1400mm from the leading edge of the door when in the fully open position.
- As a minimum, emergency assistance alarms should have a red-coloured pull cord with two red-coloured 50mm diameter bangles. The lower bangle should be set at a height of 100mm above floor level and the upper bangle should be located not less than 800mm and not more than 1000mm above floor level. Low level alarm conduits are also useful as an addition.
- A light cord pull switch should have a 50mm diameter bangle attached at a height between 900mm and not more than 1100mm above floor level. The bangle should be distinguishable through suitable visual contrast, from the background against which it is seen. The pull cord and the bangle should be distinguishable visually from any emergency assistance alarm pull cord.

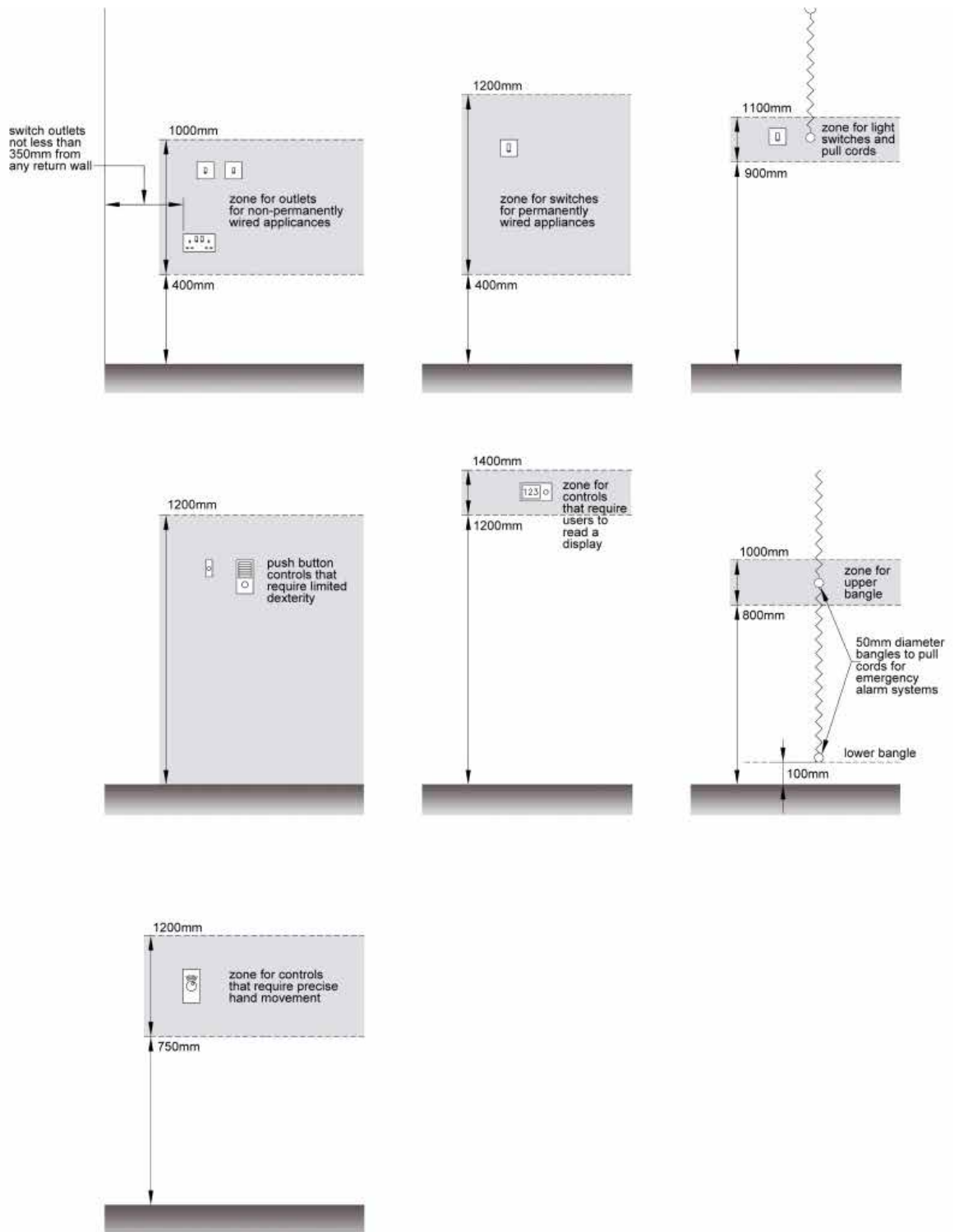

Figure 12 - Outlets, Switches and Controls



Guidance Signpost

- ▶ Access to and use of buildings. Building Regulations (Northern Ireland) 2012 Guidance: Technical Booklet R. **Paragraph 3.20**, p.24 & **Paragraphs 5.38 - 5.46**, p.46-48.

4.10 Lighting

Overview

Good lighting design is very important to assist people who are partially sighted to use sports facilities effectively and safely. Poor lighting design can cause poor visibility in a dull or dark environment, but also where there is excessive reflection or glare and where it creates shadows on floors or other surfaces, which may present a hazard. Good lighting design can be achieved by controlling the location, quality and quantity of natural and artificial light within a building.¹²

Recommended Standards

- Levels of lighting in accordance with standards should be provided on all circulation routes e.g. corridors.
- Artificial lighting should be designed to produce adequate lux levels, including within specific areas such as stairways and lifts. Illuminance at tread level should be minimum 100 lux and the general lighting level in toilet accommodation should be minimum 100 lux at floor level (i.e. the amount of light illuminating the surface at tread level).
- Both natural and artificial lighting should be controlled to avoid glare, pools of bright light and strong shadows.
- Artificial lighting should be designed to provide good colour rendering on surfaces.
- Where possible, lighting in internal rooms to which the public have access should be activated by sensitivity to movement e.g. Microwave presence sensors will detect even small movements in the extremities of a space. Recommended equipment would have an off time of 60 minutes in areas where people with disabilities have access, to avoid people being left without light.
- Avoid light sources that produce glare, e.g. wall uplighters located at floor or low level should be avoided as they may produce glare on surfaces, which can obscure vision.

¹² For lighting in sports pavilions see Sports Pavilions Guidance Notes available from Disability Sport NI.

- Where used, downlighters should be carefully located so as not to produce strong shadows.
- The illumination of floor surfaces should be as uniform as possible minimising the potential for shadows, reflection or glare, including on steps and stairs.
- In areas where one-to-one communication is important e.g. in reception areas, to aid lip reading lighting should illuminate the face of the person speaking (e.g. visitor assistant).
- Fluorescent lights may cause a 'humming' noise that can be heard by hearing aid users. This should be minimised by using high frequency fittings.
- Floodlighting should be avoided in areas where direct customer engagement takes place.
- People can lose vision as a result of lighting positioned within direct line of sight, therefore careful siting is required.
- Designers should be aware that the use of glass and steel can distort lighting.
- Light bulbs that involve a time delay on start-up should not be used e.g. time delay can be problematic for assistance dog owners and people who are partially sighted.
- Designers and management should be aware that strobe lighting can be particularly problematic for people who are partially sighted and people who have photosensitive epilepsy. See Section 4 of Guide 2: Accessible Sports Facilities Management Guidelines (2016 Edition). Sports Facilities Management Policies and Procedures - Training Plans for Staff.



Guidance Signpost

- ▶ BS 8300:2009 +A1:2010. **Paragraphs 9.4 - 9.4.4** Lighting, p.74-75.
- ▶ Lighting Guide 04: Sports Lighting. Society of Light and Lighting SLL LG4. CIBSE.
- ▶ Code for Lighting. CIBSE. The Society of Light and Lighting.

4.11 Visual Contrast

Overview

Achieving visual contrast between surfaces in and around sports facilities e.g. floor, wall, door, ceiling surfaces and fixtures, will increase the ability of people who are partially sighted to navigate around buildings independently. Vision can be enhanced through appropriate use of colour, luminance (brightness) and surface texture.

Recommended Standards

- Finishes that contrast with each other in terms of colour and tone should be used to differentiate between floors, walls, doors and ceilings.
- The colour of walls should be different from that of the ceiling and the floor.
- Doors and their frames should contrast visually with the surrounding wall.
- Where doors are designed and installed to be capable of being held-open, or where self-closers are not installed, the leading edge of doors should contrast with the rest of the door.
- Skirting should contrast visually with the floor finish, but may match or be similar in colour and tone to the wall surface.
- Corridor ends should be finished with a contrasting colour to denote a change in direction.
- Outlets, switches and controls should be distinguishable from the surrounding wall.
- Grabrails e.g. in accessible toilet units, should contrast visually with the surrounding wall surface.
- Where viewing areas are provided, contrasting row and seat numbering should be provided on seats and at ground level.
- In washroom and toilet areas, provide visual contrast between fixtures/ fittings and the background wall surface and between fittings and flooring.



Guidance Signpost

- ▶ Access to and use of buildings. Building Regulations (Northern Ireland) 2012 Guidance: Technical Booklet R. **Paragraphs 1.9, 3.4a, 3.15a, 3.2a, 4.7b(i), 4.16 - 4.18, 4.27(c), 4.28(b), 4.36, 5.40, 5.45, 6.9.**
- ▶ The Colour, Light and Contrast Manual. Designing and Managing Inclusive Built Environments. Keith Bright and Geoffrey Cook.
- ▶ Access for All: Opening Doors. A guide to support your sports club to improve physical access for disabled people. **Section 4.4.1** Visual contrast, p.30.

4.12 Floor Finishes and Court Markings

Overview

The provision of floor finishes which facilitate the safe and easy use of sports facilities by people with disabilities, including wheelchair users, ambulant disabled people and people who are blind or partially sighted is very important.¹³ Disability Sport NI recommends that each district council area should have one sports facility with a sports hall comprising wooden flooring to facilitate competitive wheelchair sports and training.

Recommended Standards

- Hard unfinished surfaces should be sealed and slip resistant.
- Floor finishes should be firmly fixed.
- Flooring should provide a firm foothold and good wheel grip. It is recommended that level dry floors should have a minimum Slip Resistance Value (SRV), also known as Pendulum Test Value (PTV), of 40. In areas that may become wet, such as entrances, changing/shower areas and poolside areas, flooring should have a minimum value of 65.
- High gloss floor finishes should be avoided as they produce glare and may be perceived as being wet and slippery even if they have a slip resistant surface.
- Where used e.g. in meeting rooms, carpets should have a shallow dense non-directional pile that will not restrict the movement of wheelchair users or present a tripping hazard to people using crutches, long canes or walking sticks/frames.
- Circulation routes should be clearly distinguishable from waiting/rest seating areas.
- Where matwells are provided the mat surface should be fixed and flush with the surrounding floor surface. Loose mats are not acceptable.
- Changes in floor colour should be used to identify a potential hazard, such as changes in level or glass screen partition locations.
- Wherever possible, floor surface colour should be used to define spatial characteristics and, where appropriate, to warn of potential hazards or assist wayfinding by giving directional information.
- Floor patterning that could be mistaken for steps, e.g. stripe patterns, should not be used.
- For floor finishes that facilitate competitive wheelchair sports see Section 8 of this guide: Sports Specific Access Information.
- Where courts are being marked out for a range of sports, floor markings should include at least one Boccia court (See Section 8.2 of this guide: Sports Specific Access Information - Boccia).

¹³ For floor finishes in sports pavilions see Sports Pavilions Guidance Notes available from Disability Sport NI.



Guidance Signpost

- ▶ Internal Floor Finishes. Specifiers' Handbooks for Inclusive Design. Centre for Accessible Environments. RIBA Publishing. 2006.
- ▶ Safer surfaces to walk on - reducing the risk of slipping (C652). CIRIA. 2006 +supplemental update 2010.
- ▶ BS 5395-1:2010. Stairs. Code of practice for the design of stairs with straight flights and winders.
- ▶ BS 8300:2009 +A1:2010. **Paragraph 7.1.1** Entrance flooring Systems, p.47.
- ▶ BS 8300:2009 +A1:2010. **Paragraph 9.1.3** Floor surfaces, p.62-63.

4.13 Acoustics

Overview

Successful acoustic design can reduce confusion and discomfort for people with disabilities navigating around and using sports facilities e.g. people who have a hearing loss, people with autism and people with dementia or learning difficulties. It is an important element that should be built into the design process.



Guidance Signpost

- ▶ BS 8233:1999. Sound Insulation and Noise Reduction for Buildings.
- ▶ BS 8300:2009 +A1:2010. **Paragraph 9.1.2** Materials and acoustic design, p.62.
- ▶ BS 8300:2009 +A1:2010. **Paragraph 11.1.11** Acoustics, p.93.
- ▶ Accessible Sports Facilities, Design Guidance Note. **Section 16** Fitness Suite: Entertainment, p.70. Sport England Publications, Wetherby. Sport England 2010.

4.14 Facilities for Assistance Dogs

Overview

While assistance dogs are commonly associated with a 'guide dog' for people who are blind or partially sighted, they can also be used by a wide range of individuals with other impairments such as 'hearing dogs' for people who are deaf or have hearing loss and 'service dogs' for people with physical disabilities. An assistance dog provides a specific service to its owner and greatly enhances their owner's ability to lead a more independent lifestyle. Provision for the needs of assistance dogs should be made in sports facilities.

4.14.1 Outdoors

Overview

A spending facility is a designated area where assistance dogs can relieve themselves.

Recommended Standards

- It is recommended that a designated spending facility (sectioned area) should always be provided as per Figure 13 of this guide: Assistance Dogs External Spending Area. However, if due to logistical or practical reasons this proves impracticable, direct consultation with Guide Dogs Northern Ireland is required to establish, agree and implement a site specific solution that takes into account positioning, security and staff support.

Additional Considerations

- Provide a designated external dog spending facility in reasonable proximity to the entrance, but within a private/non-distracting area.¹⁴
- A spending facility should be a secure area of minimum 3000mm by 4000mm with a boundary panel fencing/wall at a minimum height of 1200mm.
- Spending areas to be 50% grass surface and 50% hard standing (consult Guide Dogs on the use of alternative surface options on a site specific basis).

¹⁴ For assistance dogs' provisions in sports pavilions see Sports Pavilions Guidance Notes available from Disability Sport NI.

- A sign should be clearly displayed e.g. 'For Assistance Dogs Only'.
- Provide a slight gradient to assist drainage.
- Entrance gate should be accessible to wheelchair users and the area should have a minimum area of 1500mm by 1500mm to allow a wheelchair user to turn.
- Provide a water supply and hose.

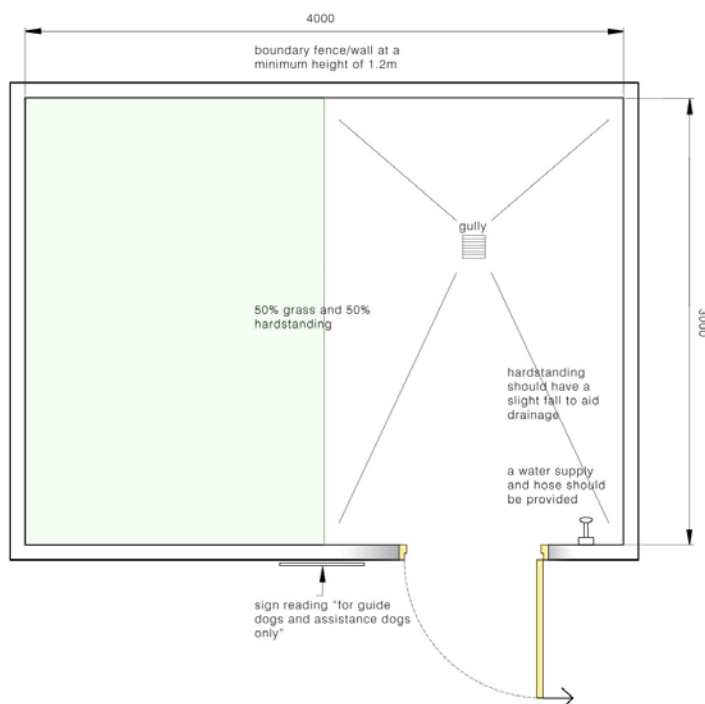

Figure 13 - Assistance Dogs External Spending Area; and spending area provision (Newry Leisure Centre)



External spending area signage

4.14.2 Within sports facilities

Overview

Assistance dog owners should have choices within sports facilities.

Recommended Standards

- Internal provision should be made available to enable an assistance dog owner to be accompanied within sports facility viewing areas, if that is their preference. Appropriate internal provision, agreed with the guide dog owner, should also be considered to accommodate a safe and secure rest space for the dogs when it is not possible for a participant to take their assistance dog with them (e.g. when swimming). This facility should be close to a staff area where supervision/monitoring can be provided and should contain a benching hook(s) and water bowl. See also Section 5.1 of this guide: Accessible Viewing Areas in Sports Facilities; Accessible Spectator/Viewing Facilities.



Guidance Signpost

- ▶ Guidance on the provision of spending facilities for Guide Dogs and other assistance dogs. The Guide Dogs for the Blind Association (Guide Dogs).

5 Accessible Viewing Areas in Sports Facilities

5.1 Accessible Spectator/Viewing Facilities

Overview

Where provision is made for spectating at a sports facility, people with disabilities should be considered. Spectators with disabilities should have a choice of accessible vantage points and should have the opportunity to sit with a companion, or within a larger group.

Recommended Standards

- The design of bleacher seating and rebound screens should be considered where temporary spectator seating is provided e.g. raised (dais) platform and ramp section integrated into the lower sections of the retractable unit to create elevated wheelchair viewing - which can be fixed to extended bleacher.
- See also Disability Sport NI Guide 3: Accessible Sports Stadia Design Guidelines (2016 Edition). Disability Sport NI. **Section 6 Accessible Viewing and Vantage Points:** 6.1 Accessible viewing capacity; Specific recommendations for ambulant accessible seating (including the provisions for persons accompanied by assistance dogs); 6.3 Sightlines; 6.4 Quiet areas, p.56-61.
- See also Disability Sport NI Guide 4: Accessible Sports Stadia Management Guidelines (2016 Edition). Disability Sport NI. **Section 5 Non-standing Policy**, p.19.

6 Accessible Communications

6.1 Signage and Wayfinding

Overview

Good external and internal signage is essential to enable people with disabilities to successfully navigate around sports facilities unassisted. 'There are four basic principles in sign design: signs should be used only when necessary; sign location should be part of the process of planning the building and the environment; messages should be short, simple and easily understood; and signs should be consistent, using prescribed typefaces, colours and contrast.'¹⁵ The use of technology can also be beneficial for wayfinding and should be considered.



Example of clear text and symbol signage (Ballymote Sports & Wellbeing Centre, Downpatrick)

Recommended Standards

Language

- Use simple wording in 'plain English' where practicable e.g. in areas where they can be readily seen and not impacted by heavy footfall.
- Wherever possible universally recognised symbols/pictograms should be used to complement wording, which will assist people with a range of abilities including people with dementia and people who do not use English. These should be large and contrasting, and embossed when within reach.

¹⁵ June Fraser, Sign Design Society.
For signage in sports pavilions see Sports Pavilions Guidance Notes available from Disability Sport NI.

- Where text is used as opposed to, or to complement pictorial signage, toilets should be signed as accessible not disabled i.e. 'Wheelchair Accessible Toilet'; 'Ambulant Accessible Toilet'; 'Wheelchair Accessible Baby Changing'.

Text

- Sentences or single word messages should begin with an upper case letter and continue with lower case.
- Words consisting totally of upper case letters should be avoided. Exceptions to this guideline are traditional, customary or specific words required by legislation and written in capital letters e.g. EXIT.
- A simple sans serif font such as Arial or Helvetica should be used.
- Lettering and numbers should reflect the guidance specified in Table 6 of this guide: Recommended Signage Font Heights.

Viewing Distance	Type of Sign	x-height (lower case letter)
Long distance	Signs seen when approaching a building (e.g. building entrances)	150mm min.
Medium distance	Directional signs (e.g. identification signs in reception areas or directional signs in corridors) *	50mm to 100mm
Short distance	Room signs*	15mm to 25mm

Table 6 - Recommended Signage Font Heights

*Embossing required for signs within reach, to enable reading by touch.

Materials

- Signs should be made from non-reflective matt finished materials.

Colour and Contrast

- Signboards should be of a colour that contrasts with the background on which they are mounted.
- Text or pictograms should contrast with the signboard.
- Designers should use tactile, coloured or tonal wayfinding tools to guide people to and around sports facilities wherever possible.
- Colours used on signs should be chosen to ensure they can be read by all people, including people with colour blindness.

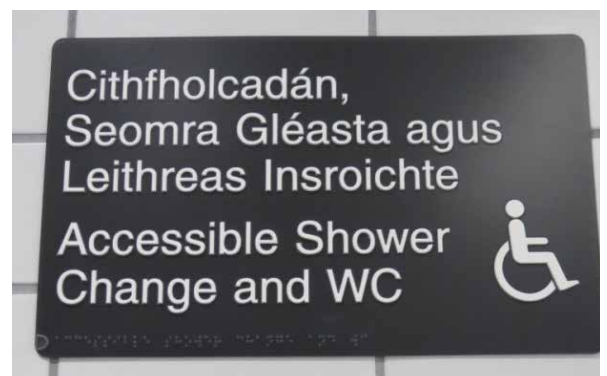
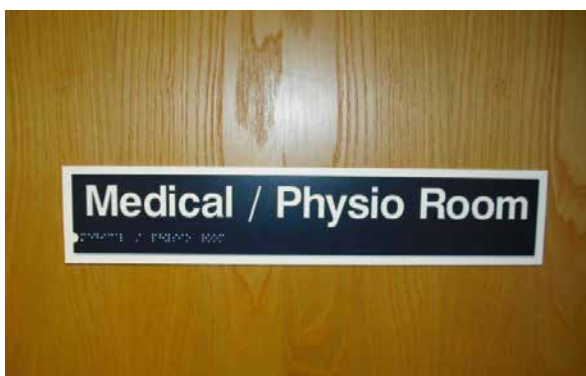

Examples of accessible room identification signage

Positioning

- Signs should be provided in prominent positions, located at key decision points e.g. at junctions of circulation routes. Signage and symbols indicating reception counter, lifts, stairs etc. should be clearly displayed in reception areas.
- Room signs positioned adjacent to doors on walls will ensure that signs can be read when a door is in the open position (complementary symbols on toilet doors will assist people with dementia).
- Designers should consider that signage may be less visible and obvious in circulation routes during periods of heavy footfall. Adequate signage, positioning and the use of complementary directional and identification signage is important.
- Signage and symbols indicating lifts, stairs and main circulation routes should be clearly displayed at the reception area.
- In general accommodation areas, signs should be mounted at or just below eye level (in the range 1400mm to 1700mm above floor level). High level signage e.g. directional signage should also be provided along circulation routes and in large busy spaces.
- Repeat directional sign at regular intervals along access routes to provide reassurance.
- No-go areas to the public should be clearly signed as 'No Entry'.

Text Ranging and Hierarchy

- For directional signs, where direction is to the left, the arrow should be on the left of the message and where direction is right, the arrow should be on the right of the message; and with message text ranged accordingly, to reduce the reading distance between the message and arrow.
- Generally, do not use centred messages for any signs.
- Use a hierarchy for directional signage listings i.e. left directional messages first, then straight ahead messages, then right directional messages etc.
- Straight ahead arrows should be to the left hand side on a directional sign and the message text left ranging.
- Where multi-lingual messages are required on signs, list like languages together on directional signboards or provide separate signboards, to avoid confusion and to reduce the appearance of clutter on signs.

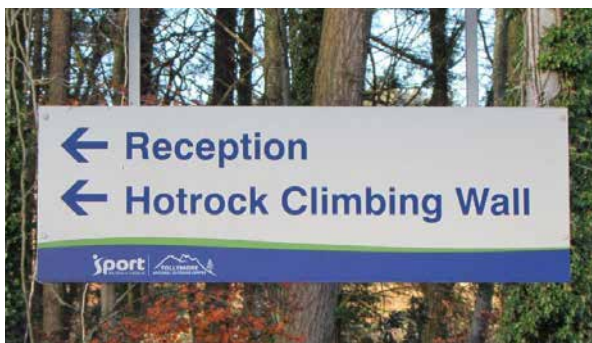

Examples of clear directional signage with arrows to reflect text ranging, Tollymore National Outdoor Centre - (images courtesy of Taylor Signs)

Signage Lighting

- Signs should be well illuminated and care should be taken that there are no bright lights behind that may dazzle the viewer.

Embossed Signs and Braille

- Signs of this type are available, but are not always practical. People who are blind or partially sighted may or may not be accompanied and due to heavy footfall signs of this type may not be locatable and/or accessible.
- Large embossed pictorial signs should be provided on doors, including Braille where appropriate e.g. on all toilet doors. This will assist people who are blind or partially sighted, people with learning disabilities and people who do not use English as their first language.
- The availability of staff assistance is very important.

Note: in areas where embossed signs and Braille may prove more viable and practical e.g. on all toilet doors, in staff areas, commercial activities areas etc., the following recommended standards are applicable:

- When signs are within reach of the user, embossed signs that can be read by touch are useful to many people who are blind or partially sighted.
- The depth of embossing should be a minimum of 1mm and the edges should be rounded.
- Standard pictograms such as those used on toilets should also be embossed.
- Grade 1 Braille should be used for single word or short multiple word signs.
- Grade 2 contracted Braille should be used to reduce the length of signs incorporating a paragraph of text.
- Incorporate Braille locators along the left-hand edge of the signboard. Locators can either be raised or recessed (by 1 to 1.5mm).



Example of tactile symbol signage with Braille - (image courtesy of Taylor Signs)

Additional Considerations

- In large sports buildings consideration should also be given to the provision of audible signs to assist people who are blind or partially sighted.



Guidance Signpost

- ▶ Sign Design Guide. A guide to inclusive signage. JMU and the Sign Design Society. Parker, P & Fraser, J.
- ▶ BS 8300:2009 +A1:2010. **Paragraphs 9.2 - 9.25** Signs and Information, p.64-69.
- ▶ See It Right - Making Information Accessible to People with Sight Problems. RNIB.
- ▶ <http://www.colourblindawareness.org>

6.2 Alarm Systems

Overview

A fire/evacuation alarm system, which can alert people who are deaf, have a hearing loss or tinnitus of possible danger, should be installed in all sports facilities. Fire alarm systems should be audible and visual, including within areas where visitors and staff may be unaccompanied.¹⁶

Emergency assistance alarms are essential in areas or facilities where people with disabilities may be alone e.g. in toilets.

Recommended Standards

- Emergency assistance alarms in sanitary accommodation, changing and shower areas should be wired to a central control point, where this is available. This will ensure that alarms are acknowledged in the event that individual alarm beacons are not seen or heard.
- A fire alarm system incorporating flashing beacons should be installed in sports facilities, including areas where people who are deaf, have a hearing loss or tinnitus might find themselves alone and therefore potentially unaware that an emergency alarm has sounded e.g. beacons should be provided in main circulation routes, toilet areas, changing and shower areas, lone offices, areas with high noise levels - ambient noise levels exceeding 90dB (A).
- Flashing beacons should be designed not to stimulate photosensitive epilepsy.



Use of flashing beacon alert within self-contained unisex wheelchair accessible WC unit



Guidance Signpost

- ▶ Access to and use of buildings. Building Regulations (Northern Ireland) 2012 Guidance: Technical Booklet R. **Paragraphs 6.4 - 6.7 & Paragraph 6.10**, p.50-51.
- ▶ BS 8300:2009 +A1:2010. **Paragraph 9.3.7.2** Emergency assistance alarm systems, p.73-74.
- ▶ BS 9999:2008. Code of Practice for fire safety in the design, management and use of buildings. **Paragraph 16.2** Fire detection and alarm systems, p.62
- ▶ BS 5839-1:2002 +A2:2008. Fire detection and fire alarm systems for buildings. Code of practice for system design, installation, commissioning and maintenance. **Section 2, Clause 17 & 18.**

6.3 Hearing Enhancement Systems

Overview

People who have a hearing loss often find it more difficult to hear in sports facilities, usually because of a combination of poor acoustics and the presence of extensive background noise. Problems can be alleviated through the provision of hearing enhancement systems such as induction loops and infrared systems, which reduce the effect of background noise so that people who have a hearing loss can hear sound more clearly.

Recommended Standards

- The most suitable system(s) will depend on the size and type of the facility, the degree of privacy required and an assessment of potential interference to the system from electrical equipment and wiring. In smaller sports facilities, a portable induction loop system which can be used in a number of different rooms may be suitable.
- An appropriate hearing enhancement system should be provided:
 - At reception.
 - At sales counters.
 - In key meeting rooms.
 - In rooms or areas used for viewing, with a permanent or temporary public address system.
- The availability of induction loops should be clearly indicated using the standard symbol.



Hearing enhancement system sign displayed at reception
(University of Ulster Sports Centre, Jordanstown)



Guidance Signpost

- ▶ BS 8300:2009 +A1:2010. **Paragraphs 9.3 - 9.3.5** Audible communication systems, p.69-73.
- ▶ Loop and infrared systems for people managing public services. Action on Hearing Loss factsheet.
- ▶ Hearing Loops: A Guide for services. Action on Hearing Loss.

6.4 Visual Aids

Overview

To assist people who are deaf, have a hearing loss or tinnitus, it is important that designers incorporate features that offer the presentation of clear, informative visual information on score boards, electronic boards, video boards and to complement audible public announcement systems. The use of large screens will assist people who may have difficulty viewing from a distance. Event commentary can serve as a visual aid for people who are blind or partially sighted.

Recommended Standards

- Where provided, large format LED TV screens that offer close viewing of sporting action should be carefully positioned to ensure visibility is not obstructed.
- Where large screens are provided, subtitles/visual information are required to complement public address systems, to assist people who are deaf, have a hearing loss or tinnitus.
- Where provided, screens and boards should be specified to reduce the likelihood of glare, especially as visual information may be critical to some people with disabilities in the event of emergency.
- A portable headphone system for use in viewing areas to relay event commentaries to.

7 Getting Out of the Sports Facility

7.1 Exit Routes

Overview

The safe evacuation of all people is an essential element of sports facility design and management. Accessible exit routes and accessible final points of exit will assist people with disabilities to make their way safely out of a sports facility, including external routes to Fire Assembly Points.

Recommended Standards

- Provide accessible exit routes and final points of exit.
- See also Section 2 of this guide: Entrance; and Section 6 of Guide 2: Accessible Sports Facilities Management Guidelines (2016 Edition). Sports Facilities Management Policies and Procedures - Emergency Evacuation Strategy.



Refuge clearly signed (The Torrent Complex, Donaghmore)

7.2 Egress

Overview

The safe evacuation of people with disabilities (who may have a broad range of need and abilities) is essential to successful sports facility design and management. Egress design will include features such as: fire signage and lighting; refuges ('safe areas'); horizontal and vertical means of escape; circulation routes; final points of exit; Fire Assembly Points etc.

Recommended Standards

- Clear signage is essential for identification and wayfinding in relation to egress and should be designed and considered as part of the overall schedule, both internally and externally.
- Visual and audible communication is required internally and externally to assist people with disabilities e.g. within refuges and at Fire Assembly Points. Lift telecoms should be linked to a central control point.
- Risk assessment and ongoing review is required in relation to all aspects of fire safety design.

Additional Considerations

- Where possible, to assist ambulant disabled people including older people, escape stairs should meet the standards for general stairs. See Section 3.3.1.4 of this guide: Stairs.
- Where a passenger lift is provided it should be a 'fire protected' lift i.e. evacuation lift (an evacuation lift will have separate electrical power supply).

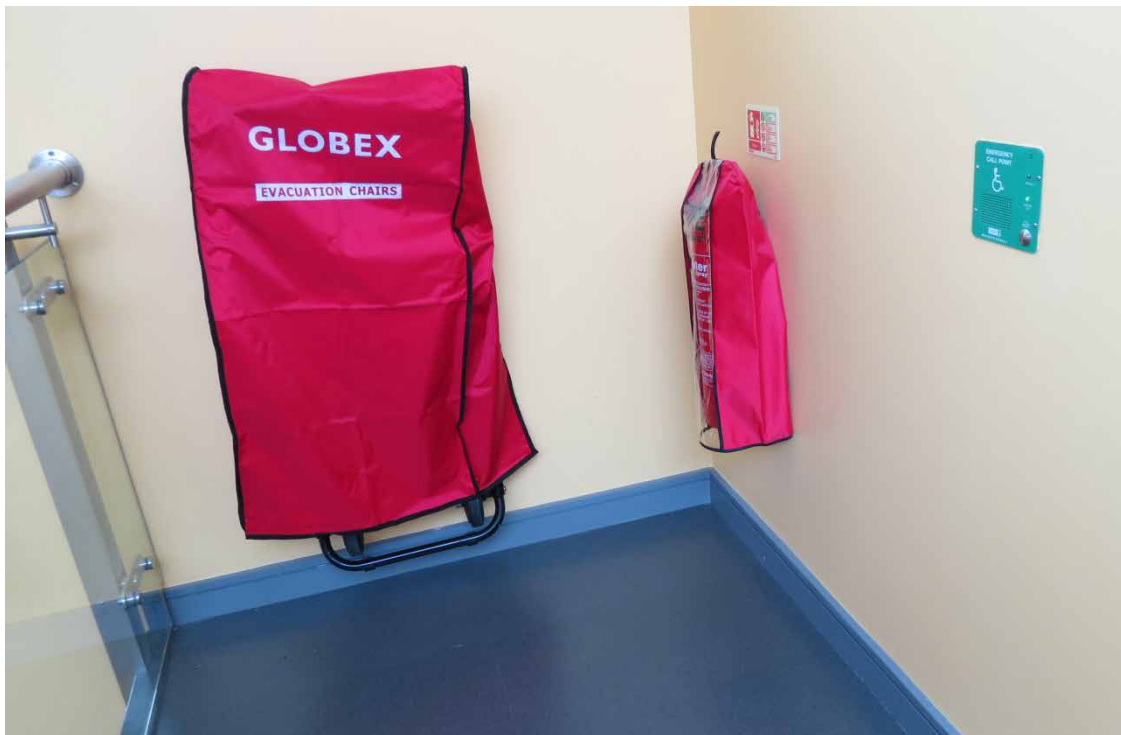

Refuge on fire escape stair landing (Foyle Arena, Derry-Londonderry)



Guidance Signpost

- ▶ The Fire Safety Regulations (Northern Ireland) 2010. DHSSPSNI.
- ▶ Fire Safety Law: The Evacuation of Disabled People from Buildings. DHSSPSNI. 2011.
- ▶ BS 9999:2008. Code of Practice for fire safety in the design, management and use of buildings. Section 9, **Paragraphs 46 - 46.12** Managing occupied buildings; Evacuation of disabled people, p.246-251.
- ▶ BS 9999:2008. **Annex D** (normative) Recommendations for theatres, cinemas and similar venues, p.320-332.
- ▶ BS 9999:2008. **Annex G** (normative) Recommendations for refuges and evacuation lifts, p.359-370.
- ▶ Safe Evacuation for All. National Disability Authority. Section 5 Equipment, Facilities and Building Design.
- ▶ Fire safety. Building Regulations (Northern Ireland) 2012 Guidance: Technical Booklet E.
- ▶ http://teachers.emdp.org/docs/Fact_sheet_Sports_Clubs_and_Fire_Safety_Final_x.pdf

8 Sports Specific Access Information

8.1 Athletics

Overview

Athletics is open to a range of people with disabilities, including people who are partially sighted, people with cerebral palsy (CP), wheelchair users and amputees and les autres. Track events include all Olympic distances while field comprises of shot put, discus, javelin, club throwing (for athletes with severe physical disabilities) pentathlon, long, high and triple jump.

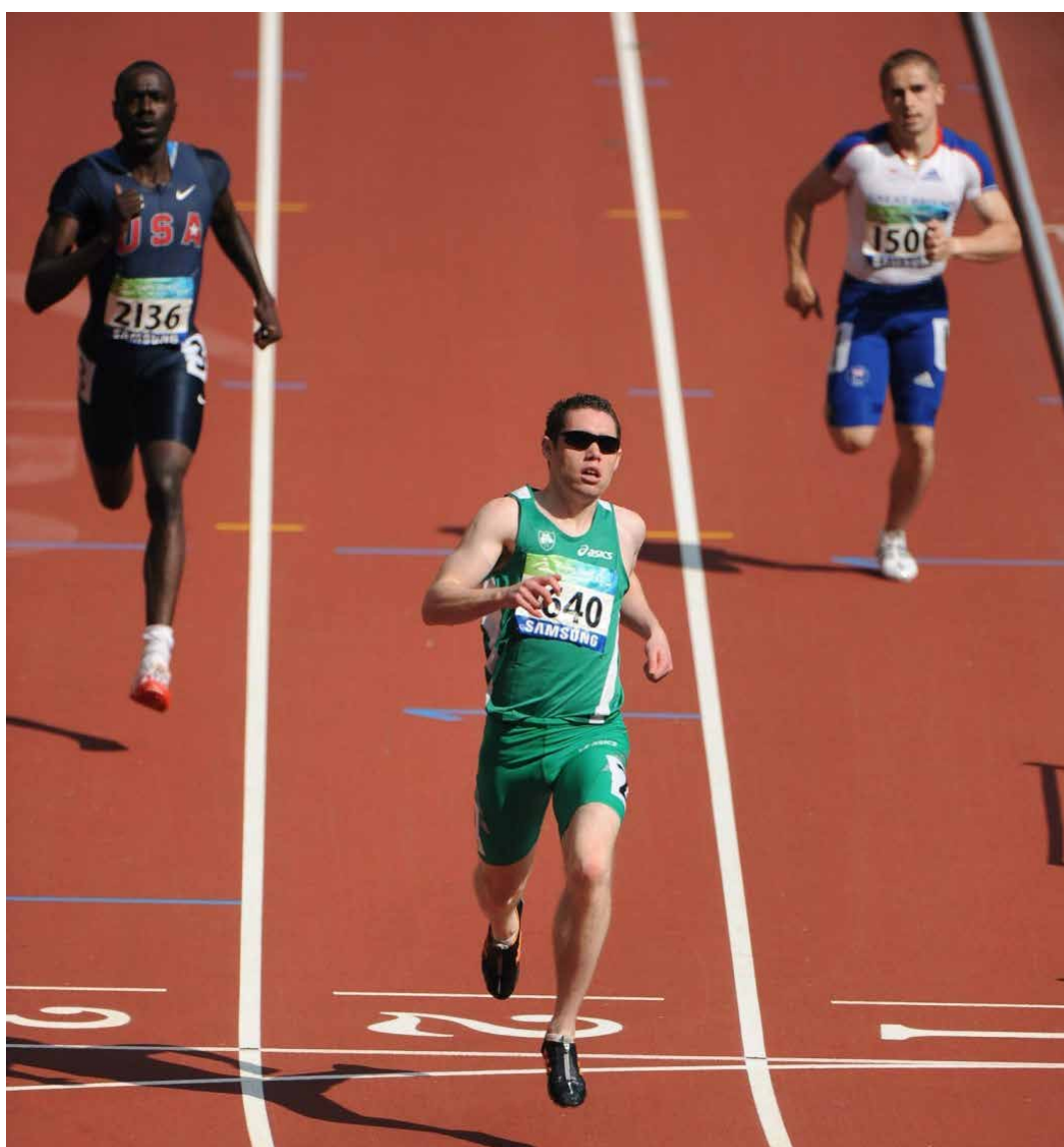

Jason Smyth competing at the London 2012 Paralympic Games
(Classification T13 athlete who is partially sighted)

General Requirements

Indoor and outdoor facilities should meet International Association of Athletics Federation (IAAF) specifications.

Specific Disability Requirements

Equipment

Throws provision must provide wheelchair anchoring facilities for disabled throwers. Athlete classification will affect the weight of shot put, javelin and discus used in training and competition. The following weights in each discipline are included in Paralympic events and should be available at the facility:

Shot Put	2kg, 3kg, 4kg, 5kg, 6kg and 7.26kg
Discus	0.75kg, 1kg, 1.5kg and 2kg
Javelin	600g and 800g
Club (for athletes with severe physical disabilities)	397g

Table 7 - Field Event Weights

Storage

Lockable storage room should be provided, to secure athletes' track and racing chairs and any other additional equipment.

Classification Area and Rooms

In order to meet the requirements of Paralympic events, the IPC (International Paralympic Committee) Athletics Classification Handbook requests a waiting area for athletes and athlete representatives, reception desk for administrative staff and four classification rooms. Each room should contain a height adjustable examination table, a desk and at least four chairs. Three of the rooms should be of equal size, with a larger room for approximately 10m by 20m required to allow for functional testing. The floor surface of the larger room should be suitable for wheeling, running, jumping, stretching, running on the spot and other gross motor activities. Hand washing facilities should be provided for classifiers in between examinations. Indoor throwing equipment is required, including indoor shot, discus, medicine balls, boccia balls and footballs. For a training facility and/or regional events one fully equipped classification room 10m by 20m in size would be adequate.



Guidance Signpost

- ▶ <http://www.paralympic.org/athletics>
- ▶ http://www.paralympic.org/sites/default/files/document/120719163715367_2011_12_05_IPC_Athletics_International_Classification_Guidelines.pdf

8.2 Boccia

Overview

Boccia is played indoors in a sports hall environment and is a game of precision where the aim is to throw, kick or use an assistive device to propel leather balls from a seated position as close as possible to a white ball that acts as a jack. Men and women compete together in team, pairs or individual events. Boccia is played at a Paralympic level by athletes with Cerebral Palsy (CP) and severe physical disabilities. BisFed (Boccia International Sport Federation) became the governing body of the Sport of Boccia in January 2013.



Members of Ulster Boccia Squad

General Requirements

Standard sports hall recommendations should be met.

Specific Disability Requirements

Equipment

Standard competition boccia balls and ramps should be available at the venue for training purposes.

Playing Surface

A flat, smooth surface (e.g. polished concrete, wooden floor or synthetic rubber) is recommended by Boccia International Sports Federation (BisFed Boccia Competition Rules February 2015), however a taraflex surface is also acceptable.

Court Dimensions

Each court measures 12.5m by 6m. A minimum of twelve courts is required in order for the facility to be suitable for international competition.

Wide tape for Exterior lines, Throwing line and V line

Thin tape for Throwing Box dividers and the 25cm by 25cm Cross

6m lines: from the inside of the side lines

12.5m side lines: from inside of the front line and inside of the back line

10m: from inside the front line to the back of the Throwing line

5m: from inside the front line to the centre of the Cross

3m: from inside the side line to the centre of the Cross

3m: from the back of the Throwing line to the front of the V line

1.5m: from the back of the Throwing line to the front vertex of the V line

2.5m: from inside the back line to inside (which is also the back) of the Throwing line

1m box lines: evenly spread over either side of the metre marks

Storage

A secure lockable room must be available to store balls and ramps.

Classification Area and Rooms

A separate private room with a height adjustable examination table and at least four chairs should be provided for classification, including hand washing facilities nearby for classifiers in between examinations.

Office space should be available for administrative staff to allow for a computerised results system.

Rest areas (separate from changing areas) should be provided for both athletes and officials during training and competition.

A Call Room with a desk should be provided for registration. The examination of all sports equipment and the coin toss will be conducted in the Call Room.

Lighting

White light is most suitable to avoid reflections and shadows, although standard sports hall lighting is also suitable.

Ventilation

Controllable heating and air-conditioning is essential.

Background Noise

Limited, but not silent, background noise.

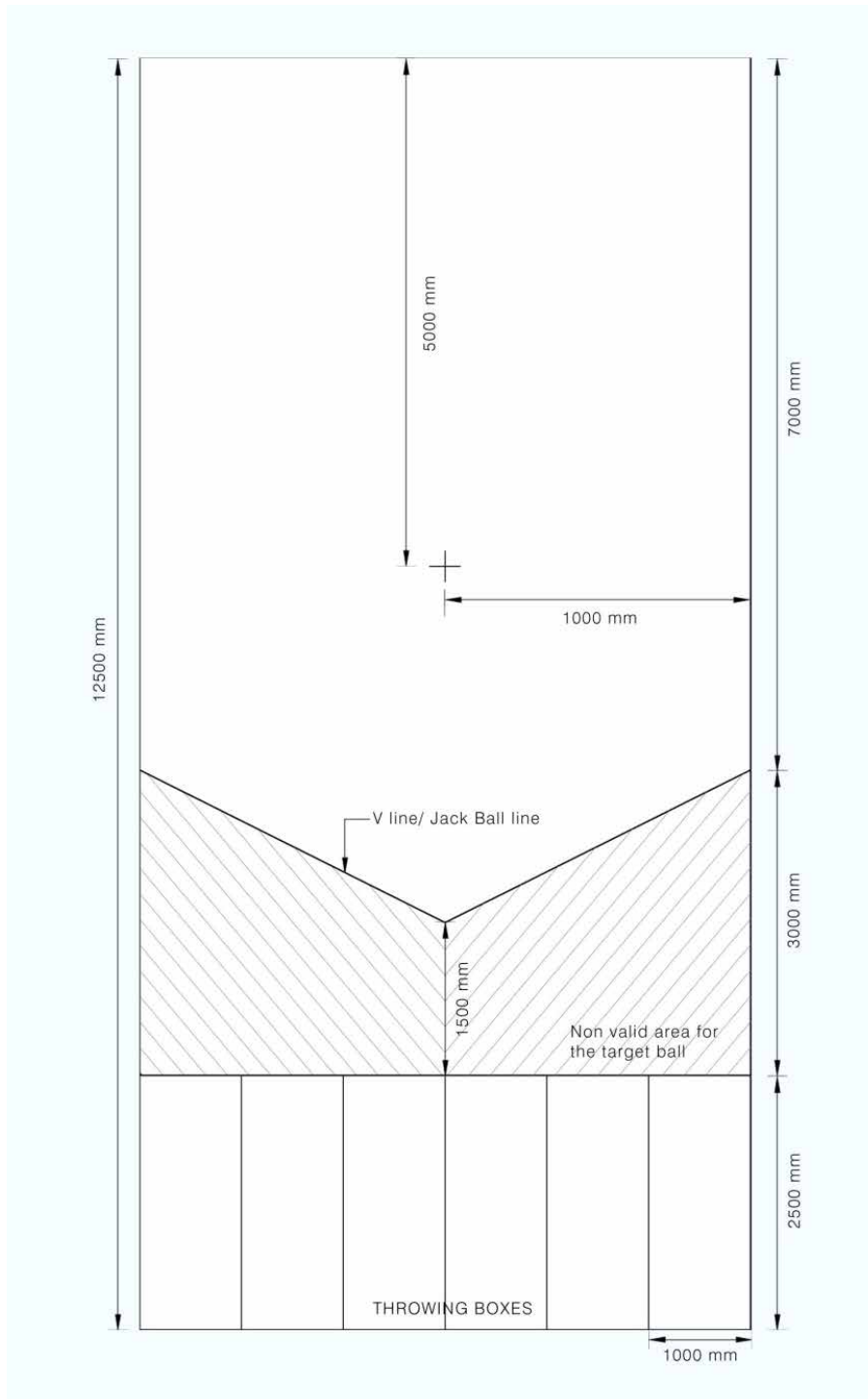

Figure 14 - Boccia Court Layout and Markings
(<http://www.bisfed.com/wp-content/uploads/2014/01/Boccia-Court-Layout.pdf>)



Guidance Signpost

▶ <http://www.bisfed.com>

8.3 Cycling

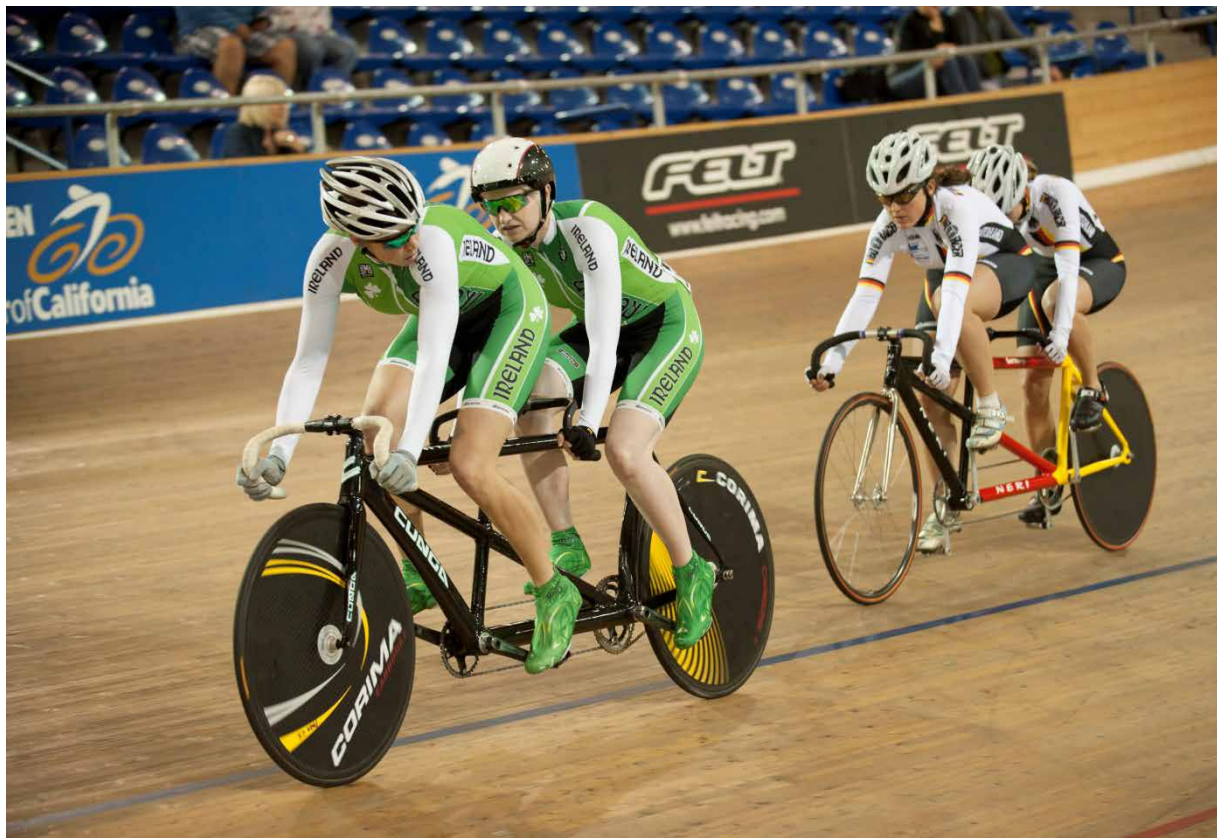

Cycling, London 2012 Paralympic Games

Overview

Track and road racing is currently open to cyclists who are blind or partially sighted, amputees, wheelchair users and athletes with cerebral palsy (CP). Depending on their classification, athletes use a bicycle, tricycle, tandem or hand cycle.



Ireland's Mark Rowan competing at the London 2012 Paralympic Games

General Requirements

Facilities should meet International Cycling Union (UCI) cycling regulations and specifications.

Specific Disability Requirements

Storage

Adequate storage should be provided for athletes' equipment, with consideration given to additional room for tandem cycles.

Classification Room

A separate private room with a height adjustable examination table and at least four chairs should be provided for classification, including hand washing facilities nearby for classifiers in between examinations.



Guidance Signpost

- ▶ <http://www.paralympic.org/sport/cycling>
- ▶ <http://www.cyclingireland.ie>
- ▶ <http://www.uci.ch/para-cycling/>

8.4 Equestrian

Overview

Athletes with physical disabilities and athletes who are partially sighted compete in freestyle, individual and team dressage events. In 2014 the FEI (International Equestrian Federation) and the IFHA (International Federation of Horseracing Authorities) joined forces to create the IHSC (International Horse Sports Confederation).



Equestrian, London 2012 Paralympic Games

General Requirements

Arena should meet FEI specification.

Specific Disability Requirements

Equipment

Scoreboards and notices should be of a size and in a location easily seen by wheelchair users. Conventional scoreboards should be used in addition to any electronic scoreboards.

Mounting blocks and/or ramps should be available during competition and training and within the stable area.

Arena Requirements

An athlete's classification will affect the size of the arena in which they compete.

Grade	Arena size:
Grade I-III	20m by 40m
Grade IV	20m by 60m

A 20m by 60m enclosed arena is used by riders who are partially sighted for training. It should be fenced with post and rails about 1.25m high and furnished with arena letters. Arenas should be sited 15m to 20m apart to avoid confusion from commanders.

Signage

Any markers used should be at least 1m high with black letters at least 0.8m high on a white background, to assist riders who are partially sighted.

Classification Room

A private examination room should be provided including a height adjustable examination bed, a table and chairs, drinking water and washing facilities nearby. Area should be large enough to accommodate at least four people.



Guidance Signpost

- ▶ <http://www.paralympic.org/sport/equestrian>
- ▶ <http://www.fei.org>

8.5 Goalball

Overview

Goalball is a 3-a-side game played by athletes who are blind or partially sighted on a volleyball sized court. The object of the game is for an athlete to throw the ball into the opponent's net using a ball with bells inside to orient the players and indicate the direction of the ball. All competitors wear eyeshades/blackout goggles while they are playing on court, allowing athletes with varying degrees of vision to participate together.



Goalball players in action

General Requirements

Standard sports hall recommendations should be met.

Specific Disability Requirements

Space Requirements

Venue dimensions for Goalball are 21m by 30m and a minimum clear head height of 5m. A Goalball court measures 18m by 9m (volleyball court) to the outside edges. The court is divided every 3m along its length to give six areas.

All lines will be 0.05m in width (+/-0.01m) and will be marked with tape. They will have string under them to assist player orientation. The string will be 0.003m (+/-0.0005m thickness) and will be placed under the top layer of tape. A tape colour should be used that provides contrast with the floor and ball, and improves the ability of referees and sighted spectators to better observe the ball and court markings.

The floor of the court must have a smooth surface and be approved by the IBSA Technical Delegate (for IBSA sanctioned competitions). For Paralympic Games, World Championships and all other Championships, a wood, plastic or synthetic resilient floor surface will be used.

Equipment

All equipment should meet the criteria established in the Rules of the Game and be certified by the IBSA Technical Delegate.

- Goal posts 1.3m high and 9m long. Posts should be made of sectional steel. The goal posts and crossbar will be round or elliptical and must not exceed 0.15m in diameter.
- The blue natural rubber ball used is a 1250g ball (+/-50gr) with a circumference 75.5cm to 78.5cm, eight sound holes and two noise bells. For major championship tournaments (Paralympic Games, World Championships and Paralympic Games qualification tournaments) an IBSA approved ball determined by the organising committee will be used.
- For the benefit of spectators and coaches, a visual scoring system must be maintained. The scoreboard must be visible at all times from the team bench area.
- Three clocks. The first clock is the official time/game clock and must be visible at all times from the team bench area. The second clock is a backup clock, which is not official unless required by the referee who can then designate it as official. For the Paralympics and World Championships the main clock shall be a basketball type clock with a 10th of a second count down during the last minute. A third clock must be placed in the coin toss area and will be the official clock used for coin tosses.
- Substitute boards.
- Benches for team areas.

Team Area

The Team Area is 6m (+/-0.05m) long by 9m (+/-0.05m) wide with its back edge being the goal base line. Team Areas are divided into two equal sections. These sections will be called the Orientation Area and the Landing Area. The Orientation Area is closest to the goal and the Landing Area is furthest from the goal.

Team Bench Area

Each team will have a team bench area, which will be positioned on either side of the officials' table, a minimum of 3m from the court's side line. It will be 4m long (+/-0.05m) and 3m (+/-0.05m) deep and will be marked by a tape line with string.

Player Orientation Lines

Two outward position lines are located in the team area 1.5m (+/-0.05m) from the team area front limitation line. These lines shall be 1.5m (+/-0.05m) in length and run inward from the outside limitation line towards the middle of the team area. The lines shall be on each side of the team area.

Furthermore, two centre position lines shall be included in the team area. These shall be in the middle of the team area running inward from the team area front limitation line and the goal base line, perpendicular to these lines. They shall be 0.5m (+/-0.05m) in length. Additionally, there shall be two 0.15m lines (+/-0.05m) extending perpendicularly towards the goal line 1.5m (+/-0.05m) in from the side line on the front limitation line of the team area.

Landing Area

Immediately adjacent, but lying in front of the team area, is the Landing Area. This is an area 9m (+/-0.05m) wide by 3m (+/-0.05m) in depth.

Neutral Area

The Neutral Area is the middle area of the court. It is 6m (+/-0.05) long by 9m (+/-0.05m) wide and is divided in two by the centre line.

Line-out Line

Around the entire court there should be a non- tactile tape line 1.5m (+/-0.05m) beyond the side and goal lines.

Spectators

Spectators must be restricted to an area no closer than 4m from any part of the court. This area will be clearly tactile marked, or fenced, so that spectators do not encroach on or near the playing area.

Background Noise

The venue will be acoustically suitable for Goalball. Air conditioning or heating will be quiet so as not to impact on the games if it is to be used during a tournament.

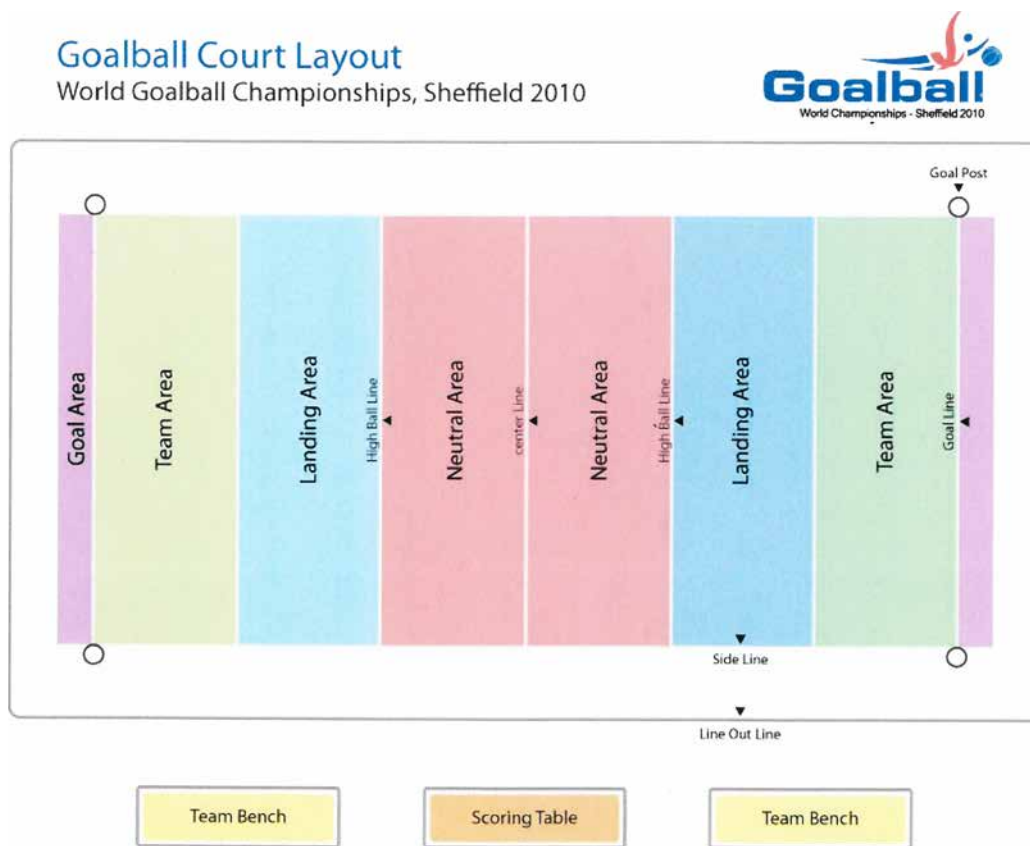

Figure 15 - Goalball Court Layout



Guidance Signpost

- ▶ <http://www.ibsasport.org/sports/goalball/>
- ▶ Email: goalball@ibasport.org

8.6 Gymnastics



Gymnast in action

Specific Disability Requirements

Gymnastics is not currently a Paralympic sport. There are therefore, no specific disability requirements, however full consideration should be given to access requirements to ensure the facility is suitable for any future changes in the sport.

A disability gymnastics programme has been in place at British Gymnastics since 1985. Previously known as Gymnastics & Movement for People with Disabilities it now has the name 'Disability Gymnastics'. The programme ensures that gymnastics is adapted to meet the needs of each gymnast.

Through the delivery of disability gymnastics, coaches can enable all disabled gymnasts to achieve their full potential, focusing on what they can do, not on what they can't do. From fundamental movement activity to elite gymnastics skills, disability gymnastics has something exciting, fun and engaging for all disabled people to enjoy; it is also widely recognised as providing many physical and social benefits for participants, such as developing increased coordination skills and building confidence. Disability gymnastics is a far more recognisable and inclusive title for this exciting programme. It also follows the social model terminology for disability, which is socially acceptable and truly reflects the inclusive nature of the programme.

Disability gymnastics is 'pan-disability', meaning that any disabled person can take part if they cannot access mainstream gymnastics. All gymnastics disciplines can be adapted to include disabled people in the sport and competitive opportunities exist within men's artistic, women's artistic, rhythmic, trampoline, teamgym and acrobatic gymnastics. The disability gymnastics pathway provides training and competition opportunities for gymnasts that cannot adequately access mainstream gymnastics, creating a level playing field for all to enjoy gymnastics and achieve.

I'M IN is the new Disability Gymnastics programme from British Gymnastics, which aims to create more participation opportunities for more disabled people in Gymnastics. The programme will support a network of gymnastics clubs and coaches to plan and deliver quality gymnastics opportunities for disabled people.



Guidance Signpost

- ▶ <http://www.ukgymnastics.org/>
- ▶ <http://www.fig-gymnastics.com>

8.7 Rowing

Overview

Adaptive rowers compete in four Paralympic boat classes: men's arms only single scull (ASM1x); women's arms only single scull (ASW1x); trunk and arms mixed doubles (TA2x) and legs, trunk and arms mixed coxed 4 (LTA4x). Each class races over a distance of 1000m.



Para Rowing, London 2012 Paralympic Games

General Requirements

Fédération Internationale de Societes d'Aviron (FISA) specification areas to be met.

Specific Disability Requirements

Water Access

To ensure access to the water, a non-slip pontoon of suitable width for wheelchair transfer and of good transfer height (180mm off water level) should be used. Alternatively, a hard shingled accessible slipway to the water is suitable. Although in most cases wheelchair users will already have an established transfer technique, hoists should also be available to assist with transfer from land to boat.

Paralympic Boats Standard Adaptive 4+

The FISA Standard Adaptive 4+ used at the Paralympic Games regatta is a stern-coxed boat. The design and specifications are stipulated by FISA.

Standard Adaptive 2x

The FISA Standard Adaptive 2x has a fixed seat and may have stabilising pontoons. The hull, the pontoons where fitted and the seat fixing are part of the Standard specifications. The design and specifications shall be stipulated by FISA.

The seat itself and the rigger design of the standard 2x are not restricted.

The TA2x boat shall have a seat to which the athlete is strapped at the hips to fix the pelvis so that the rower is not able to use the foot stretcher for leverage. The method of strapping shall be of a design which allows immediate release with single hand movement in case of emergency.

Standard Adaptive 1x

The FISA Standard Adaptive 1x has a fixed seat and must have stabilising pontoons. The pontoons must be fixed in position so that when the rower is seated in the balanced boat both pontoons shall be horizontal and shall, at a minimum, touch the water. The hull, the pontoons and the seat fixing are part of the Standard specifications. The design and specifications shall be stipulated by FISA. The seat itself and the rigger designs are not restricted.

The seat design and its manner of use must meet the following requirements:

The design of the seat of the A1x is unrestricted except that it must be compatible with the Standard seat fixing. In order to ensure that the arms only aspect of the A1x boat class are fully met, the A1x boat shall have a high seat back to which the athlete is strapped so that only the arms and shoulders can move during rowing. The strap should be at the level of the diaphragm, directly below the nipples or breasts and be tight enough to restrict any trunk movement without causing breathing problems. The method of strapping shall be of a design which allows immediate release with single hand movement in case of emergency.

The minimum weights for Adaptive Boats are:

4 x 51kg

2 x 36kg

1 x 22kg

Boats shall include pontoons where used.

Safety Equipment

All adaptive rowers are encouraged to wear self-inflating or other flotation device for additional safety. These should be stored in a suitable area, which is accessible and within reach of wheelchair users.

Safety Boats

Additional safety boats may be required on the course for all adaptive events, but particularly A1x events.

Classification Room

A separate private room with a height adjustable examination table and at least four chairs should be provided for classification, including hand washing facilities nearby for classifiers in between examinations.



Guidance Signpost

▶ <http://www.worldrowing.com/para-rowing/>

8.8 Sailing

Overview

Athletes compete in three sailing events:

The 'Single-Person' and 'Three-Person' Keelboats are open to most disability groups, whilst the 'Two-Person' Keelboat event is specifically designed for athletes with a severe disability.

The sailing classification system is based on four factors: stability, hand function, mobility and vision. The Single-Person and Three-Person disciplines are open to any gender, however the Two-Person discipline requires at least one female within the crew.

The sport is governed by the International Association for Disabled Sailing (IFDS), which closely co-operates with the International Sailing Federation (World Governing Body for Sailing).



Sailing on the Craigavon lakes

Specific Disability Requirements

Space Requirements

- Jetties should be stable and wide enough for two wheelchairs to pass safely. Depressions in the surface should be sufficiently narrow to avoid tripping people and jamming wheelchair castors. A raised edge guides sailors who are partially sighted and reduces the chances of wheelchairs (occupied or otherwise) being 'lost overboard'.
- Avoid wide, unstable bumpers, such as rubber tyres, as they increase the space between the boat and the jetty and make transfers more difficult.
- Ramps to the jetty should have handrails. The surface of the ramp should have transverse strips wide enough to give a good footing for a walker, but short enough to allow the wheels of a chair to pass over easily.
- Shore - if a boat must be launched from the shore it is essential that a firm, smooth beach is selected for the purpose. Old carpets can be laid over soft or muddy surfaces. Heavy duty rubber matting provides a longer lasting solution.

Equipment

The boats utilised for the three events are:

- Single-Person Keelboat - 2.4mR
- Two-Person Keelboat - SKUD-18 (formerly known as the UD-18)
- Three-Person Keelboat - 23ft Sona

Adaptations

At present, boats widely used are the Paralympic three-person keelboat, the Sonar; the Paralympic single-person keelboat, the 2.4mR, Martin 16, Ideal 18, Access Dinghy, Rhodes 19, Hobie Trapseat and the Freedom. Included are seats, transfer benches, hiking and steering assists; also used on some boats such as the Martin 16 is joystick steering plus electronics for sip and puff.

- Seats allow the sailors to position themselves so they can control the tiller and sheet without fear of falling. These can be as simple as a lawn chair modified to fit a cockpit or as complex as a translating seat, which allows a sailor to switch sides. Seats include the lawn chair, wheelchair bases, go-kart seats and other easily adapted seats.
- The transfer bench allows sailors to switch sides when tacking or jibing and can be anything from a sturdy cooler in the middle of the cockpit, a custom cockpit filler to platforms that fill in the cockpit area.
- Steering devices take many forms, including a collapsing metal tiller, which allows free movement from one side of the boat to another or wheel steering. One steering system uses levers on both sides of the boat. Handholds and bars provide stability for the sailor in the sailing position, or in a move from one side to the other. Sheet fine tune and other systems provide assistance to sailors with weakness or poor muscle function; these comply with relevant class and IFDS rules.
- Boat hook - to aid disembarking in adverse wind conditions.

Cushions

Cushions are vital pieces of equipment for sailors with disabilities. They are essential for skin protection for those with no sensation due to paralysis, important for the comfort of someone with limited movement sitting for long periods and useful for someone with lack of trunk stability, or in need of support to maintain a particular position e.g. to reach winches or sheets.

- The Jay Protector (JP) is a small pad filled with a patented gel. The pad fits inside a sling which is strapped to the body to protect the sailor's buttocks. The JP provides protection in the wheelchair during transfer on the jetty and in the boat. It is designed to be worn outside protective clothing and will

protect waterproofs. Some sailors wear a JP underneath their waterproofs to make sure it is not displaced during manoeuvres.

- A Roho is an inflatable rubber cushion (therefore unaffected by water) with the appearance of an egg box. It provides excellent protection and comfort in the boat. Care must be taken to avoid punctures. It is available in regular and 'active' profiles.
- It is useful to have spare cushions available during transfers to use as 'stepping stones' for sailors who need constant protection. Ordinary foam wheelchair cushions can be used, but they tend to soak up water. Alternatives include layers of closed cell foam glued together. Holes drilled through this 'sandwich' prevent water settling on the surface and provide a means of tying the cushion securely to the seat of the boat.

Aids to Transfer

If people with disabilities sail regularly from a fixed venue it may be worth considering permanent aids to transfer. Such aids vary from simple to complex. Lifting puts helpers at risk of injury, but if mechanical lifting devices are not simple, at hand and practical they will not be used.

- A sliding board is useful where the transfer gap is wide and the deck is at a similar height to the seat of the chair.
- A transfer box provides trunk support.
- A webbing loop (2m of 500mm webbing joined end to end) can be passed under the armpits and behind the knees.
- A bosun's chair or medical sling can be used for transfer. It is sometimes simpler to keep the sling around the body while sailing so that it is ready for disembarkation.
- A block & tackle can be rigged on the boom or main halyard and used in conjunction with the above 'suspending' devices.
- A hoist can be installed on a stable dock or floating pontoon, however this may be unsuitable for a floating pontoon. A hoist is particularly useful if mounted on the outside corner of a dock where it can be used for both the front and side.
- Cranes for launching boats can be used for transferring people.
- A gantry is useful ashore in preparation for a beach launch.



Guidance Signpost

- ▶ <http://www.sailing.org/disabled>

8.9 Swimming

Overview

Swimming is an important activity for many disabled people at competition level, or purely for recreation. It is open to athletes with physical disabilities and athletes who are blind or partially sighted. Athletes compete in all four strokes.



Bethany Firth competing at the London 2012 Paralympic Games (Classification S14 Athlete)

General Requirements

Fédération Internationale de Natation (FINA) facility regulations should be adhered to.

Specific Disability Requirements

Equipment

Hoists should be available at each end of the pool.

Wetside chairs and storage provision.

Mats. The mats are to be a minimum of 1m wide and 2m long and shall be placed on the deck beside the outside lanes of the pool, within 1m of each end.

A strobe/starting light for swimmers who are deaf, have a hearing loss or tinnitus. The light is required to be able to be transferred next to the starting platform of the swimmer and positioned to the swimmer's requirement.

Ventilation

It is essential that the air-conditioning system does not re-circulate air, as this contaminates the pool hall air.

Classification Area

A private examination room should be provided including a height adjustable examination bed, a table and chairs, drinking water and washing facilities nearby. Area should be large enough to accommodate at least four people.



Guidance Signpost

▶ <http://www.paralympic.org/Swimming>

8.10 Table Tennis

Overview

Table Tennis competitions take two forms at the Paralympic Games: Standing and Wheelchair events (sitting).

Individual and team, men's and women's events are included.

The International Table Tennis Federation and International Paralympic Table Tennis Committee govern the sport.



Wheelchair Table Tennis players in action

General Requirements

International Table Tennis Federation (ITTF) facility regulations should be adhered to.

Specific Disability Requirements

Equipment

- The height of one or maximum two cushions is limited to 14cm in playing conditions with no other addition to the wheelchair.
- Racket/bat can be taped to the hand of player, if required.
- Tables shall allow access to wheelchairs without obstructing the player's legs and shall allow access to two wheelchairs for doubles.
- Table legs shall be at least 40cm from the end line of the table for wheelchair players.

Surface

A concrete floor is, in principle, acceptable for wheelchair events.

Space Requirements

For wheelchair play the playing space may be reduced, but shall be not less than 8m long and 7m wide.



Guidance Signpost

- ▶ http://www.ittdream.com/ITTF_Dream_Building/PTT_Main.html

8.11 Volleyball

Overview

Volleyball was introduced into the Paralympic Games in Arnhem in 1980. Originally, both Standing and Sitting competitions were included in the Games, however Standing Volleyball was removed from the programme following the Sydney 2000 Paralympic Games.

Volleyball is governed by World ParaVolley. World ParaVolley administrates four disciplines of Volleyball for the physically impaired - Sitting and Standing indoor and Standing and Sitting Beach. Rules for each of the disciplines are based on the FIVB (Fédération Internationale de Volleyball) rules.



GB and Netherlands ParaVolley teams competing in Sitting Volleyball at the London 2012 Paralympic Games - (image courtesy of World ParaVolley Sport Director)

General Requirements

World ParaVolley Rules of the Game, Rules and Regulations and Facility Regulations to be adhered to. Rules of the Game are available for all four ParaVolley disciplines.

Specific Requirements (Sitting Volleyball)

Space Requirements

- In Sitting Volleyball the court is smaller (6m by 10m) than a standard volleyball court and has a net positioned at a height of 1.15m for men and 1.05m for women, so the game is considerably faster than the Standing equivalent.
- The free playing space is the space above the playing area, which is free from any obstructions and light fittings should not pose any danger to players. The free playing space shall measure a minimum of 7m in height from the playing surface.
- For World ParaVolley World and Official Competitions, as well as Zonal Championships, the free zone shall measure a minimum of 4m from the side lines and 6m from the end lines. The free playing space shall measure a minimum of 10m in height from the playing surface.
- The surface must be flat, horizontal and uniform. It must not present any danger of injury to the players. It is forbidden to play on rough or slippery surfaces. For World ParaVolley World and Official Competitions, as well as Zonal Championships, only a wooden or synthetic surface is permitted. Any surface must be previously approved by World ParaVolley.
- The playing area includes the playing court and the free zone. It shall be rectangular and symmetrical.

Net

- Placed vertically over the centre line there is a net with its top set at a height of 1.15m for men and 1.05m for women.
- The net is 6.5m to 7m long and 0.80m wide.
- Net height is measured from the centre of the playing court.
- Net height (over the two sidelines) must be exactly the same and must not exceed the official height by more than 2cm.
- The posts supporting the net are placed at a distance of 0.50m to 1m outside the sidelines. They are 1.25m high and preferably adjustable.
- The posts are rounded and smooth, fixed to the ground without wires. There shall be no dangerous or obstructing devices.
- The attack lines are drawn 2m from the axis of the centre line.
- On indoor courts the surface of the playing court must be of a light colour.
- White colours are required for the lines. Other colours, different from each other, are required for the playing court and the free zone.

Temperature

The minimum temperature shall not be below 10°C (50°F). For World ParaVolley World and Official Competitions, as well as Zonal Championships, the maximum temperature shall not be higher than 25°C (77°F) and the minimum not lower than 16°C (61°F).

Lighting

For World ParaVolley World and Official Competitions, as well as Zonal Championships, the lighting on the playing area should be 1000 to 1500 lux, measured at 1m above the surface of the playing area.



Guidance Signpost

- ▶ <http://www.worldparavolley.org/>
- ▶ World ParaVolley General Manager: generalmanager@worldparavolley.org

8.12 Wheelchair Basketball



Northern Ireland Wheelchair Basketball players competing at the 2015 School Games held at Sports City Manchester

Overview

Wheelchair Basketball is played by athletes with lower limb disabilities and also by those with 'permanent' sports injuries which prevent them from playing the running game of Basketball.

It is one of the highest profile sports at the Paralympics: 12 Men's teams and 8 Women's teams qualify through regional qualification events. Players are classified according to their physical disability through a scale from 1.0 - 4.5 pts (1.0 pointers having the highest level of disability and 4.5 pointers, the least). A team on court comprises five players and the total 'team' points value cannot exceed 14 pts.



Northern Ireland Under-15's at National Junior Championships 2015, Worcester

General Requirements

Fédération Internationale de Basketball (FIBA) facility regulations should be adhered to.

Specific Disability Requirements

Equipment

A lockable storage room should be provided for secure storage of wheelchairs and other associated equipment. This room needs to be large enough to hold thirty 'stored' wheelchairs and should be accessible to wheelchair users.

The scoring table shall be provided with a device (directional arrow) to display the direction of play for the next possession under the alternating possession procedure.

Wheelchair Basketball is played on a regulation-sized hardwood basketball court. It is essential that there is at least a 4m run-off area behind each basket. If the court is 'raised', as per many show courts, it is essential that there is suitable access for Basketball/Rugby Wheelchairs.

Classification Area

A private examination room should be provided including a height adjustable examination bed, a table and chairs, drinking water and washing facilities nearby. Area should be large enough to accommodate at least four people.

Changing Rooms

In large venues designed for major competitions a four team changing room should be provided, each with two fully equipped unisex wheelchair accessible toilets.



Guidance Signpost

▶ <http://www.iwbf.org>

8.13 Wheelchair Rugby

Overview

Wheelchair Rugby is a team sport for male and female quadriplegics. It is a unique sport created by athletes with disabilities that combines some elements of Basketball, Rugby and Ice Hockey. The sport is played with a volleyball on a standard basketball court with goals and key areas marked out at both ends. Teams of four players compete, with the aim being to score goals by crossing the opposing team's goal line while in possession of the ball. The ball may be passed, thrown, batted, rolled, dribbled or carried in any direction, subject to the restrictions laid down in the rules. Two wheels must cross the goal line for a goal to count and the player must have firm control of the ball when he or she crosses the line.



Ulster Barbarians Wheelchair Rugby players in action

General Requirements

Fédération Internationale de Basketball (FIBA) facility regulations should be adhered to.

Specific Disability Requirements

Equipment

The game is played with a white ball identical in size and shape to regulation volleyball. In addition to the ball, four cones, pylons or other similar markers are required to mark the ends of the goal lines.

The scoring table should be provided with a device (directional arrow) to display the direction of play for the next possession under the alternating possession procedure.

Surface

Wheelchair Rugby is played indoors on a regulation-sized basketball court. Hardwood is the preferred playing surface, although other surfaces are acceptable. The playing surface must be accessible to wheelchair users. Any facility which can be used for Wheelchair Basketball will be sufficient for Wheelchair Rugby.

Space Requirements

Wheelchair Rugby is played on a regulation hardwood basketball court measuring 28m by 15m, with at least a 5m run-off area behind each goal. The court is marked with boundary lines, a centre line, a centre circle and two key areas.

The centre line divides the court into a front court and back court area. A team's back court includes their goal line and key area. Teams score in their front court, which includes the opponent's goal line and key area. The centre line is considered to be part of the back court.

The key areas are located on the two end lines. They are 8m wide and 1.75m deep. The part of the end line that is in the key area is called the 'goal line'. The ends of the goal line are marked by two cones.

Classification Area

A private examination room should be provided including a height adjustable examination bed, a table and chairs, drinking water and washing facilities nearby. Area should be large enough to accommodate at least four people.



Guidance Signpost

▶ <http://www.iwrf.com/>

8.14 Wheelchair Tennis



Ivor Jess competing in the final of the Belfast Open at the Belfast Indoor Tennis and Ozone Complex

Overview

Wheelchair Tennis is played in Singles and Doubles format at the Paralympics in Male, Female and Quad sections. It is also played in all four Grand Slams - the Australian Open; Roland Garros; Wimbledon and the US Open; and has a global tour of 160 tournaments in 40 countries.

Wheelchair Tennis is a sport where wheelchair users and non-disabled players can play and compete together, with the non-disabled person permitted one bounce and the wheelchair player allowed two bounces.



Nathan McCabe and Ross Gourley competing at the 2015 School Games

General Requirements

International Tennis Federation (ITF) facility regulations should be adhered to.

Specific Disability Requirements

Surface

Athletes should have non-marking tyres on their tennis wheelchairs. Wheelchair Tennis can be played on all surfaces: hard, clay and grass.

Equipment

Consideration should be given to the appropriate positioning, in terms of height and location, of any equipment or apparatus within or associated with the facility in terms of wheelchair users.

Space Requirements

Wheelchair Tennis is played on a regulation-sized tennis court. Access to the court area should be via a level surface with no steps at the main entrance to the court area. Tennis wheelchairs are amongst the widest chairs used and can be in the region of 1200mm wide. The specification for buildings accommodating wheelchair tennis players should be increased accordingly. The width of chairs should also be considered when determining appropriate clearance distance between the player area, umpire area and court change-over point.

Note: Recommended Standards provided in Section 2.2: Lobbies; Section 2.3: Visitor Reception; Section 3.1: Corridors and Passageways; Section 3.2: Internal Doors; and Section 3.3.1: Passenger Lifts are based on maximum sports chair widths of 1000mm, however where sports facilities will accommodate wheelchair tennis activities, design specifications appropriate to tennis wheelchairs are required i.e. minimum 1200mm.

Floodlighting columns should not restrict the minimum width required.

Event Venue

Facilities on Site

Accessible toilets, changing rooms and shower facilities should be available, as well as locker rooms reserved only for players.

Sun Protection

There must be adequate provision of shade.

Wheelchair Storage

There must be a secure place for players to store their tennis wheelchairs overnight.

Repair Station

A repair station is required on site and an air compressor available at all times.

Scoreboards

Scoreboards should be provided on all show courts. At Grand Slams, Super Series and Singles Masters and Doubles Masters the scoreboards should display players' names.

Catering

There must be facilities accessible to players to purchase food (e.g. café or restaurant).

Player Lounge

There must be a player lounge available on-site.

ITF Tournament Representatives Office/Desk

If an ITF Tournament Representative is attending the tournament an office/desk should be arranged (with Internet access).

Practice Courts

A minimum of one practice court per 60 players shall be available free of charge to players from at least one day before the start of the event until the completion of the event. Practice courts must be of the same surface as the match courts. It is preferable that the practice courts are on site. If the practice courts are at a different venue to the match courts, free transportation must be provided.

Court Preparation and Court Layout

All courts must be well prepared prior to the match (clay-courts must be prepared, water on court, bins emptied etc.).

Floodlights

If matches are to be played under artificial lighting, the intensity of illumination must be sufficient for professional tennis i.e. minimum of 500 lux, and distributed evenly over the court.



Guidance Signpost

- ▶ <http://www.itftennis.com/wheelchair>
- ▶ <http://www.itftennis.com/wheelchair/organisation/rules-regs.aspx>



Ruairi Logan (Scotland) competing at the 2015 School Games

Appendices

- Appendix A Guidance Signpost Bibliography
- Appendix B Useful Websites
- Appendix C Useful Resources

Appendix A

Guidance Signpost Bibliography

Access for All: Opening Doors. A guide to support your sports club to improve physical access for disabled people. English Federation of Disability Sport and Sport England. 2013.

Accessible Sports Facilities (formerly known as Access for Disabled People). Design Guidance Note. Sport England. Updated 2010 guidance. April 2010.

Access to and use of buildings. Building Regulations (Northern Ireland) 2012 Guidance: DFP Technical Booklet R: 2012.

Architectural Ironmongery. Specifiers' Handbooks for Inclusive Design. Centre for Accessible Environments and RIBA Publishing. Alison Grant. 2005.

Automatic Door Systems. Specifiers' Handbooks for Inclusive Design. Centre for Accessible Environments and RIBA Publishing. Alison Grant. 2005.

BS EN 81-1:1998 +A3:2009. Safety rules for the construction and installation of lifts. Electric lifts.

BS EN 81-2:1998 +A3:2009. Safety rules for the construction and installation of lifts. Hydraulic lifts.

BS EN 81-70:2003. Safety rules for the construction and installation of lifts. Particular applications for passenger and goods passenger lifts. Accessibility to lifts for persons including persons with disability.

British Standards Institute. BS 5839-1:2002 +A2:2008. Fire detection and fire alarm systems for buildings. Code of practice for system design, installation, commissioning and maintenance.

British Standards Institute. BS 5395-1:2010. Stairs. Code of practice for the design of stairs with straight flights and winders.

British Standards Institute. BS 8233:1999. Sound Insulation and Noise Reduction for Buildings. Code of practice.

British Standards Institute. BS 8300:2009 +A1:2010. Design of Buildings and their Approaches to meet the needs of Disabled People. Code of practice.

British Standards Institute. BS 9999:2008. Code of practice for fire safety in the design, management and use of buildings.

Cafe Culture: Memorandum of Understanding. Belfast City Centre Management.

Changing Places: the practical guide. Changing Places Consortium.

Code for Lighting. CIBSE. The Society of Light and Lighting. 2012.

CSN EN 16005. Power operated pedestrian doorsets - Safety in use - Requirements and test methods. 2012.

DD CEN/TS 15209:2008. Tactile paving surface indicators produced from concrete, clay and stone.

Disability Sport NI Guide 3: Accessible Sports Stadia Design Guidelines (2016 Edition). Disability Sport NI.

Fire safety. Building Regulations (Northern Ireland) 2012 Guidance: DFP Technical Booklet E: 2012.

Fire Safety Law: The Evacuation of Disabled People from Buildings. Department of Health, Social Services and Public Safety Northern Ireland. 2011.

Glazing. Building Regulations (Northern Ireland) 2012 Guidance: DFP Technical Booklet V: 2012.

Guidance on the provision of spending facilities for Guide Dogs and other assistance dogs. The Guide Dogs for the Blind Association (Guide Dogs).

Guidance on the use of tactile paving surfaces. Department for Transport. 2007.

Hearing Loops: A guide for services. Action on Hearing Loss.

Inclusive Mobility: A guide to best practice on access to pedestrian and transport infrastructure. Department for Transport. 2005.

Internal Floor Finishes. Specifiers' Handbooks for Inclusive Design. Centre for Accessible Environments and RIBA Publishing. Ann Alderson. 2006.

Lighting Guide 04: Sports Lighting. Society of Light and Lighting SLL LG4. CIBSE 2006.

Loop and infrared systems for people managing public services. Action on Hearing Loss factsheet. Action on Hearing Loss.

Safe Evacuation for All. National Disability Authority (Ireland). 2011.

Safer surfaces to walk on - reducing the risk of slipping (C652). CIRIA. 2006 + supplemental update 2010.

See It Right - Making Information Accessible to People with Sight Problems. RNIB. 2006.

Sign Design Guide. A guide to inclusive signage. JMU and the Sign Design Society. Parker, P & Fraser, J. 2000.

Sports Clubs and Fire Safety Factsheet. English Federation of Disability Sport. 2013. http://teachers.emdp.org/docs/Fact_sheet_Sports_Clubs_and_Fire_Safety_Final_x.pdf

Stairs, ramps, guarding and protection from impact. Building Regulations (Northern Ireland) 2012 Guidance: DFP Technical Booklet H: 2012.

The Colour, Light and Contrast Manual. Designing and Managing Inclusive Built Environments. Keith Bright and Geoffrey Cook. 2010.

The Fire Safety Regulations (Northern Ireland) 2010. Department of Health, Social Services and Public Safety (NI).

Appendix B

Useful Websites

www.actiononhearingloss.org.uk (formerly RNID)

Action on Hearing Loss. For product solutions: www.actiononhearingloss.org.uk/shop.aspx

www.ageuk.org.uk/northern-ireland

Age NI - charity combining Age Concern NI & Help the Aged in Northern Ireland

www.adni.org.uk

Assistance Dogs Northern Ireland

www.assistancedogs.org.uk

Assistance Dogs UK - A voluntary coalition of assistance dog organisations

www.autismni.org

Northern Ireland's Autism Charity

www.bisfed.com

Boccia International Sports Federation

www.cae.org.uk

Centre for Accessible Environments

www.changing-places.org

Changing Places Consortium

www.colourblindawareness.org

Colour Blind Awareness

www.cyclingireland.ie

Cycling Ireland

www.dementiafriends.org.uk

Dementia Friends. An Alzheimer's Society initiative

www.disabilityaction.org

Disability Action

www.dsni.co.uk

Disability Sport NI

www.efds.co.uk

English Federation of Disability Sport

www.epilepsy.org.uk

Epilepsy Action Northern Ireland

www.fei.org

Federation Equestre Internationale

www.fig-gymnastics.com

International Gymnastics Federation

www.guidedogs.org.uk

Guide Dogs for the Blind Association

www.hearingdogs.org.uk

Hearing Dogs for Deaf People

www.ibsasport.org

International Blind Sports Federation

www.imtac.org.uk

Inclusive Mobility and Transport Advisory Committee

www.iwrf.com

International Wheelchair Rugby Federation

www.itftennis.com/wheelchair

International Tennis Federation (wheelchair)

www.itfdream.com

International Table Tennis Federation's Social Responsibility Program

www.levelplayingfield.org.uk

Level Playing Field (Promoting Good Access For All Fans)

www.mencap.org/northernireland

Mencap Northern Ireland. The Voice of Learning Disability

www.niassistancedogs.btck.co.uk

Northern Ireland Assistance Dogs

www.nrac.org.uk

National Register of Access Consultants

www.nifrs.org

Northern Ireland Fire & Rescue Service

www.nrcpd.org.uk

The National Registers of Communication Professionals Working with Deaf and Deafblind People

www.rnib.org.uk/accessiblewebsites

Royal National Institute for Blind People

www.rnib-business.org.uk/training-overview

Royal National Institute for Blind People

www.sailing.org/disabled

Official Website of World Sailing (Para World Sailing)

www.sportscotland.org.uk

Sports Scotland

www.uci.ch/para-cycling

Union Cycliste Internationale (Para-cycling)

www.ukgymnastics.org

UK Gymnastics

www.worldparavolley.org

World ParaVolley

www.worldrowing.com/para-rowing

World Rowing (Para-rowing)

www.communities-ni.gov.uk

Department of Communities

www.finance-ni.gov.uk/topics/building-regulations-and-energy-efficiency-buildings

Department of Finance (Building Regulations)

www.planningni.gov.uk

Department for Infrastructure (Northern Ireland Planning Portal. Planning NI)

www.infrastructure-ni.gov.uk/topics/public-transport

Department for Infrastructure (Public Transport)

Appendix C

Useful Resources

Access to leisure facilities for guide dog owners and other blind and partially sighted people. The Guide Dogs for the Blind Association (Guide Dogs).

Active Design: Planning for Health & Wellbeing Through Sport & Physical Activity. Public Health England & Sport England. October 2015.

Briefing Paper. Concessionary Charging Policy. Disability Action. 2012.

British Standards Institute. BS 7000-6:2005. Design management systems. Managing inclusive design. Guide.

British Standards Institute: Publicly Available Specification PAS 78:2006. Guide to Good Practice in Commissioning Accessible Websites.

Building Sight, A Handbook of Building and Interior Design Solutions to include the needs of Visually Impaired People. Peter Barker, Jon Barrick and Rod Wilson. Royal National Institute of the Blind and HMSO. 1995.

Disability Discrimination (NI) Order 2006.

Disability Sport NI Guide 2: Accessible Sports Facilities Management Guidelines (2016 Edition). Disability Sport NI.

Disability Sport NI Guide 4: Accessible Sports Stadia Management Guidelines (2016 Edition). Disability Sport NI.

Disability Sport NI Boxing Facilities Guidance Notes (2016 Edition). Disability Sport NI.

Disability Sport NI Sports Pavilions Guidance Notes (2016 Edition). Disability Sport NI.

Glass in Buildings. Specifiers' Handbooks for Inclusive Design. Centre for Accessible Environments and RIBA Publishing. Ann Alderson. 2006.

Good Loo Design Guide. RIBA Enterprises and Centre for Accessible Environments. Andrew Lacey. 2004.

Inclusive Design and Access Statements Guidance.

<http://www.sportscotland.org.uk/sportscotland/Documents/Resources/FacilitiesReport03AccessGuidance.pdf>

Inclusive Design Standards. London Legacy Development Corporation. March 2013.

<http://www.queenelizabetholympicpark.co.uk/-/media/Ildc/policies/Ildcinclusivedesignstandardsmarch2013.ashx?la=en>

Inclusive Design Standards. Olympic Delivery Authority. 2008.

Making Your Club More Accessible to Disabled People. Level Playing Field.

Making Your Club More Accessible - Top 10 Tips. Level Playing Field.

Making Your Club More Accessible - Top 10 Tips for Cricket. Level Playing Field.

Making Your Club More Accessible - Top 10 Tips for Rugby. Level Playing Field.

Mencap's Make It Clear. Mencap Communication Guide. Mencap's Make It Clear. Mencap Communication Guide.

<http://www.advocacyproject.org.uk/wp-content/uploads/2014/06/make-it-clear-apr09.pdf>

Northern Ireland Census (2011).

Pavilions and Clubhouses. Design Guidance Note. Sport England. June 1999.

Platform Lifts. Specifiers' Handbooks for Inclusive Design. Centre for Accessible Environments and RIBA Publishing. Alison Grant. 2005.

Providing Accessible Parking: A good practice guide. The Baywatch Campaign (NI). Inclusive Mobility and Transport Advisory Committee (IMTAC) in Northern Ireland. [http://www.imtac.org.uk/downloads/Parkingguide\(finalversion\).pdf](http://www.imtac.org.uk/downloads/Parkingguide(finalversion).pdf)

Stairs, ramps and escalators: Inclusive design guidance. Centre for Accessible Environments and RIBA Publishing. Ann Alderson. 2010.

The Disability Discrimination Act 1995. Assistance Dogs Owners - their rights: Employers and Service Providers - best practice. Equality Commission for Northern Ireland. Updated December 2014.

The Prevalence of Disability and Activity Limitations Amongst Adults and Children Living in Private Households in Northern Ireland. Northern Ireland Statistics & Research Agency. Bulletin 1 July 2007.

Notes

Notes

Notes

Notes



Disability Sport NI

Unit F, Curlew Pavilion
Portside Business Park
189 Airport Road West
Belfast BT3 9ED

Telephone: 028 9046 9925

Textphone: 028 9046 3494

Email: email@dsni.co.uk

www.dsni.co.uk



Supported by

